



Advanced Metalworking Solutions for naval systems that go in harm's way

S2291 - Remote Welding Preheat Control System

NSRP – Welding Technology Panel Meeting
Idaho Falls, Idaho
August 17, 2010

Navy Metalworking Center / Concurrent Technologies Corporation

Distribution Statement C: Distribution Authorized to U. S. Government Agencies and Their Contractors; Administrative Use: 17 August 2010. Other Requests for this Document Shall be Referred to: Office of Naval Research Code O3T MT.

DESTRUCTION NOTICE - For Unclassified, Limited Distribution Documents, destroy by any method that will prevent disclosure of contents or reconstruction of the document.

Navy Metalworking Center A ManTech Center of Excellence



Concurrent Technologies Corporation

- Presentation Goal
- Project Team
- Background and Issue
- Project Objective
- Approach
- Conceptual Solutions
- Key Issues
- Down Selection Status
- Technical Discussion / Feedback

Presentation Goal

- Provide project background and issue
- Review technical approach and potential solutions
- Request feedback regarding potential for implementation at your shipyard
- Request technical feedback to support conceptual design of system

Integrated Project Team

- **Future Aircraft Carriers Program Office (PMS 378)**
 - Blenda Gately - Stakeholder Representative
- **Naval Sea Systems Command (NAVSEA) 05V3**
 - Joe Lojek - Project Oversight
- **Naval Surface Warfare Center, Carderock Division**
 - Richard Wong - Technical Assistant (TA)
- **Northrop Grumman Shipbuilding - Newport News**
 - Anna Yarashus, N.P. Rao, Mike Jones, Paul Hebert, Gary Smith - Technical Execution / Implementation Organization
- **Navy Metalworking Center**
 - Chad Scott, Clark Boriack - Project Management / Technical Execution
- **General Dynamics Electric Boat**
 - Barry Espeseth, David "Doc" Holliday, Steve D' Angelo - Promote Technology Transfer

- Current ManTech sponsored project is focusing on CVN78 Class construction
- Intent of ManTech projects is to promote wider implementation of project results
- Preheating of weld assemblies required during construction
- Current process uses electric heater bars
- No closed loop control in-place
 - Monitored by using temperature sticks
 - Controlled by percentage timers or plugging and unplugging heater bars
- Non-metallic materials packaged in certain weldments

- High labor cost associated with monitoring pre-heat temperatures
- Significant risk associated with overheating
 - Causes damage to non-metallic materials, causing a root cause analysis investigation and rework
- Additional labor costs and schedule impacts associated with overheating
- Unnecessary energy consumption associated with present monitoring and control method

Project Objective

- Reduce labor costs associated with controlling weld preheat temperature
- Reduce the risk of overheating non-metallic materials within a weld assembly in an effort to reduce rework costs



- Demonstrate capability to monitor and control preheat temperature using a prototype remote welding preheat control system in a production environment
- Implement by procuring and using full production-sized control system

- Establish Requirements
- Identify Potential Solutions
- Down Selection
- Detail Design
- Build Prototype
- Conduct Lab Tests and Finalize Prototype
- Conduct Field Tests of Prototype
- Transition Technology

Project Requirements

- 75 KW capacity – 30 heaters, 2.5 KW/heater
- 480 VAC / 100 A / 3 phase input power
- 50 lb weight limit for carrying components
- One thermocouple per heater
- Temperature control of +/- 25 °F
- Localized control with alarms
- Data Acquisition
 - Compatible with existing LabVIEW system
 - Ethernet communication
- Outdoor rated and compatible with existing environment
 - 32 to 100 °F ambient temp.
 - High humidity and condensing water
 - Dust including carbon, metal grindings, etc.

- Conceptual Solutions
 - Commercially available systems
 - Systems currently on the market that satisfy requirements as sold
 - Commercially available systems with modifications
 - Commercially available systems that can be modified by integrating additional components or systems to meet requirements
 - Custom assembled/fabricated systems with commercial off-the-shelf (COTS) or custom parts
 - Specify and integrate COTS components to meet system requirements

- Commercially Available Systems include
 - Hotfoil – www.hotfoil.com

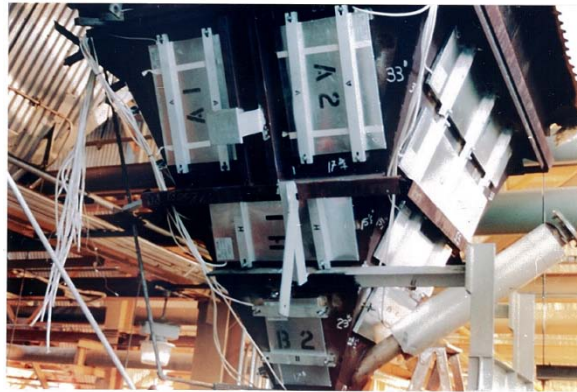

- Commercially Available Systems include
 - Superheat – www.superheatfg.com

Data Can Be Misleading... Source of Material Defects

SUPERHEAT FGI

PO#	120843	SO#	SI 2340	LINE#	04	123457600 2	PWOL	P91-1	STARTED	16:40 04/05/2006	FIG 5#	SC 3104
CUSTOMER	Company Name		Material	Chrome - P91	WELD	FW-16	FINISHED	03:36 04/06/2006	Cal date	05:18 04/01/2006	File Name	sc 3104 0504051640a3
Description: Detailed Description of Weld or Work Piece as Required by Customer												

T/C#	Cable#
1	25
2	26
3	27
4	28
5	29
6	30

04/06/2006 Superheat FGI Inc

Buttons: Backup Data, Load, Print



New innovations improve results...

Introducing, Tomorrow's heat treating technology ... Today!

Internet Based Quality Management Model

Thermocouple Heaters, Smart Light™, Super View™

Tomorrow's heat treating technology. Today.

Commercially Available Systems

- Commercially Available Systems include
 - Miller Welds – www.millerwelds.com



SYSTEM REQUIREMENTS/CAPABILITIES		Desired	Superheat	Hotfoil-EHS (Six Way Power Console)
Communications	Format	Ethernet	Proprietary	Ethernet
Electrical (System Ratings)	Input Voltage (3-phase VAC)	480	480	440/480/575
	Service Required (A)	<200	60	90
	Rated Power (kW)	75	46 kW	73 kVA
	Number of Heaters	30	12	30
Electrical (Heater Ratings)	Output (Heater) Voltage (single-phase VAC)	480	85	40-240
	Resistive heating	Heater Bar	85V heating elements	Lower voltage heating elements
Physical Specifications	Weather Rated	Outdoors	Indoor	Outdoor
	Durable Casing	Yes	metal	metal
	Weight Restrictions (max)	50 lbs	650 lbs	960 lbs
	Size Restrictions	none	(36" x 24" x 24")	(24" x 26" x 57")
Closed loop Requirements	t-couple type	Type K Thermocouple	YES	YES
	t-couple quantity	1 per Heater Bar (max)	6 (1 per 2 heaters)	12 (1 per 2.5 heaters)
Temperature Requirements	Maximum Temperature	250F	2000 F	1900 F
	Temperature Range	+/- 25F	+/- 5 F	+/- 0.25%



COTS Systems

SYSTEM REQUIREMENTS/CAPABILITIES		Desired	Hotfoil-EHS (Twelve Way Power Console)	Mannings (High Voltage Unit)
Communications	Format	Ethernet	Ethernet	RS232, RS485
Electrical (System Ratings)	Input Voltage (3-phase VAC)	480	440/480/575	480
	Service Required (A)	<200	150	120 A (for maximum output)
	Rated Power (kW)	75	91 kVA	100 kVA
	Number of Heaters	30	30	30
Electrical (Heater Ratings)	Output (Heater) Voltage (single-phase VAC)	480	40-240	277
	Resistive heating	Heater Bar	Lower voltage heating elements	Existing heaters
Physical Specifications	Weather Rated	Outdoors	Outdoor	Indoor
	Durable Casing	Yes	metal	metal
	Weight Restrictions (max)	50 lbs	1400 lbs	500 pounds
	Size Restrictions	none	(24" x 28" x 57")	(24" x 26" x 49")
Closed loop Requirements	t-couple type	Type K Thermocouple	YES	YES
	t-couple quantity	1 per Heater Bar (max)	24 (1 per 1.25 heaters)	12 (1 per 2.5 heaters)
Temperature Requirements	Maximum Temperature	250F	1900 F	2000 F
	Temperature Range	+/- 25F	+/- 0.25%	+/- 1 F

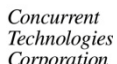
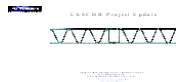



COTS Systems

SYSTEM REQUIREMENTS/CAPABILITIES		Desired	Mannings (Low Voltage Unit, 17000)	Millers (ProHeat35, Air Cooled)
Communications	Format	Ethernet	RS232, RS485	none
Electrical (System Ratings)	Input Voltage (3-phase VAC)	480	460/575	400-575
	Service Required (A)	<200	125.5 A (for maximum output)	60-40
	Rated Power (kW)	75	100 kVA	35 kW
	Number of Heaters	30	30	4
Electrical (Heater Ratings)	Output (Heater) Voltage (single-phase VAC)	480	Selectable 60 or 80	Induction heating blanket
	Resistive heating	Heater Bar	Existing heaters	Induction heating blanket
Physical Specifications	Weather Rated	Outdoors	Indoor	Outdoor
	Durable Casing	Yes	metal	metal
	Weight Restrictions (max)	50 lbs	1000-1600 lbs	227 lb
	Size Restrictions	none	(27" x 25" x 52") to (64" x 35" x 52")	(27.5" x 21.75" x 36.75")
Closed loop Requirements	t-couple type	Type K Thermocouple	YES	YES
	t-couple quantity	1 per Heater Bar (max)	12 (1 per 2.5 heaters)	4 (1 per heater)
Temperature Requirements	Maximum Temperature	250F	2000 F	400F (air cooled)
	Temperature Range	+/- 25F	+/- 1 F	+/- 3 F



Modified COTS System

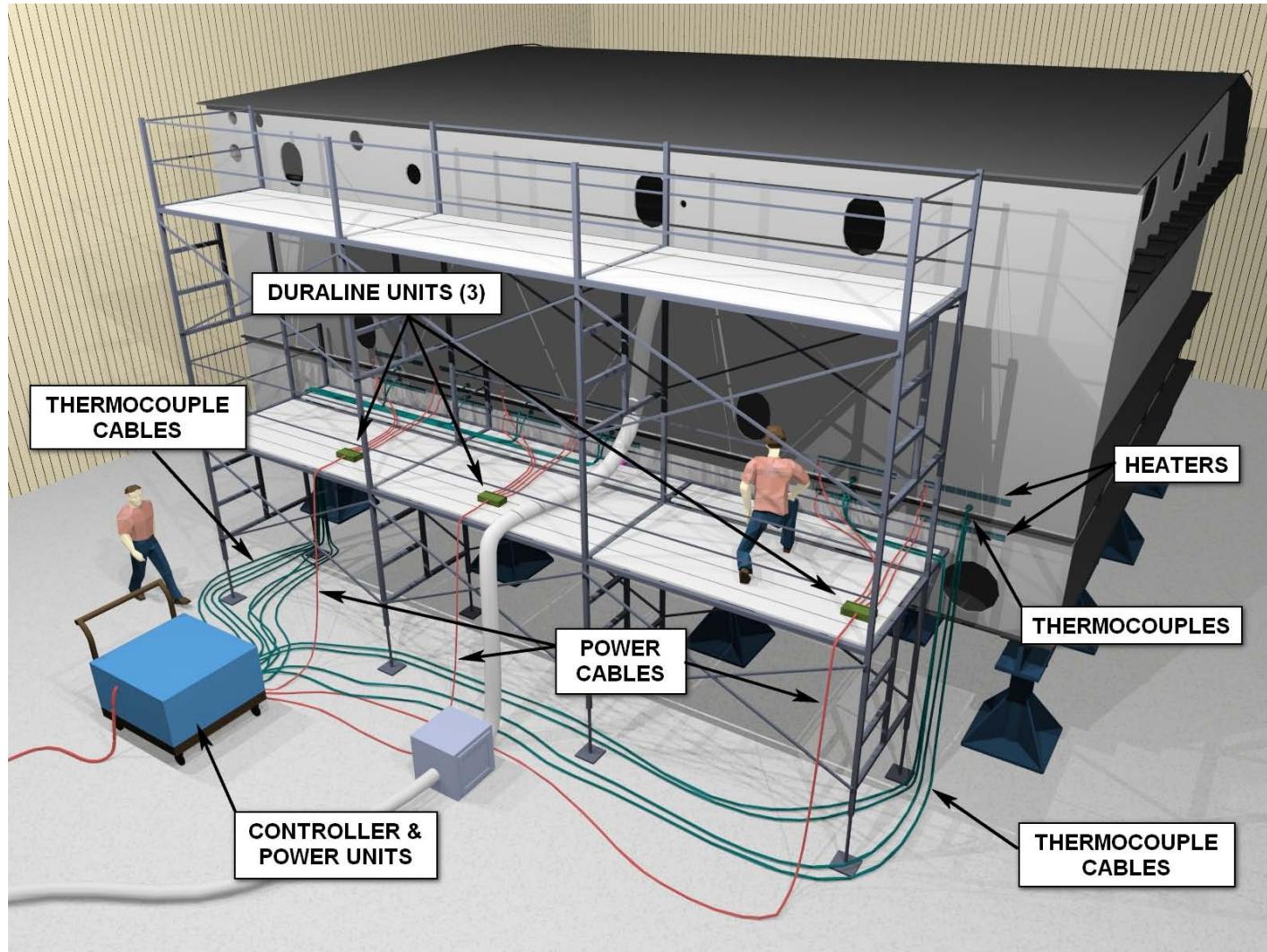

Modified COTS System: Disadvantages

- Highest weight (>500 lbs)
- Indoor rated
- Maximum 3 zones of control
 - Up to 18 2.5 KW heaters on each zone (potential for wide temperature variation)
- Potential Wiring issues
 - Multiple similar connectors on controller
 - Long cables, messy
 - Must be careful to match thermocouple boxes with correct heater elements and with correct zone

Modified COTS System: Disadvantages

- Cannot use full power output of unit due to 480V/100A input power available
- Contactor control (On/Off vs Continuous)
- Logistics Issues –
 - Setup and operation requires detailed procedures
 - Cannot modify configuration once unit is turned on
- Requires reverse engineering and modification
 - Add PLC for control and alarms
 - Add data acquisition system
 - Add communication

Single Unit Version

(centralized power, control, temperature)

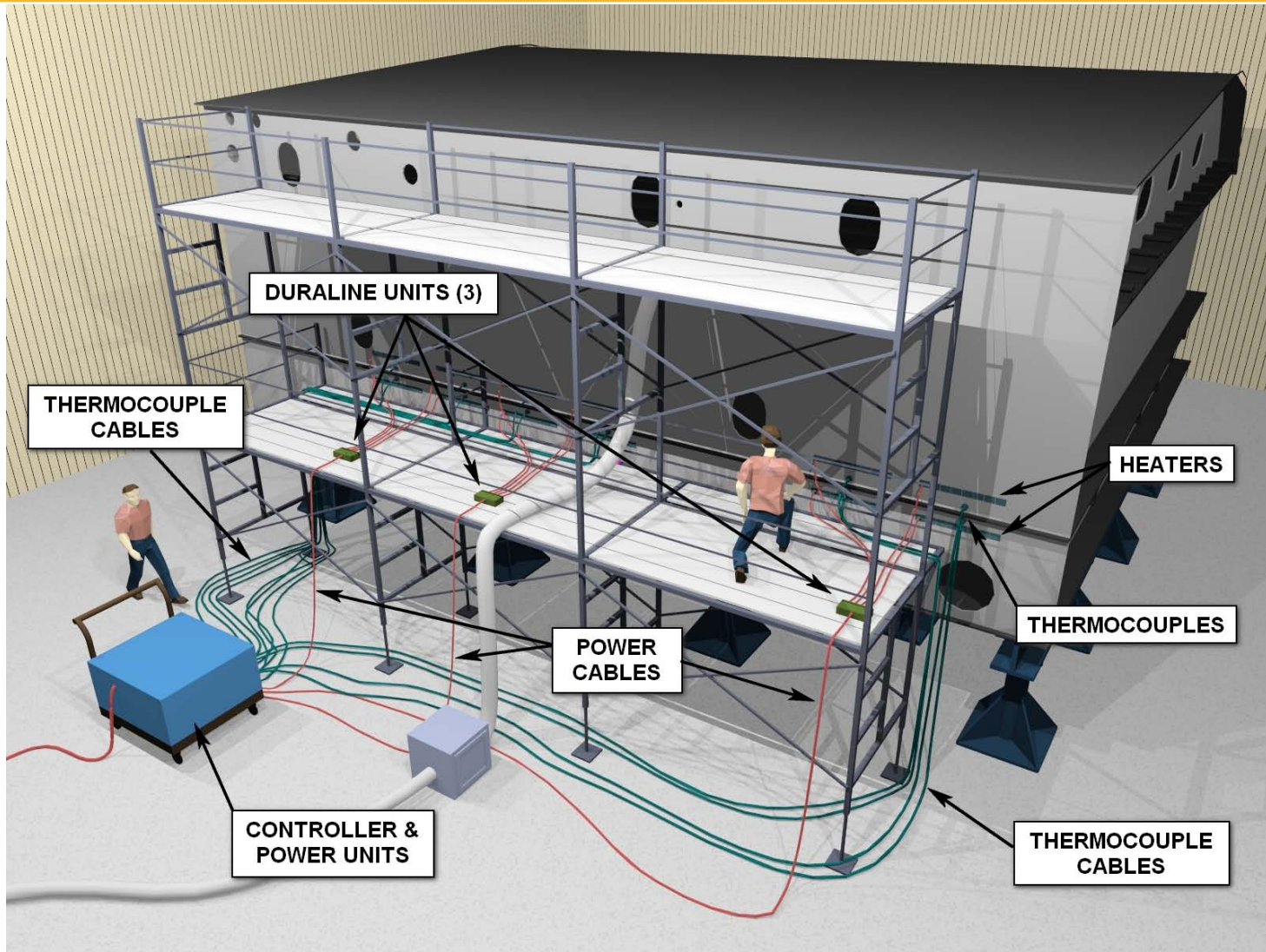

Single Unit Version

(centralized power and control; distributed temperature)

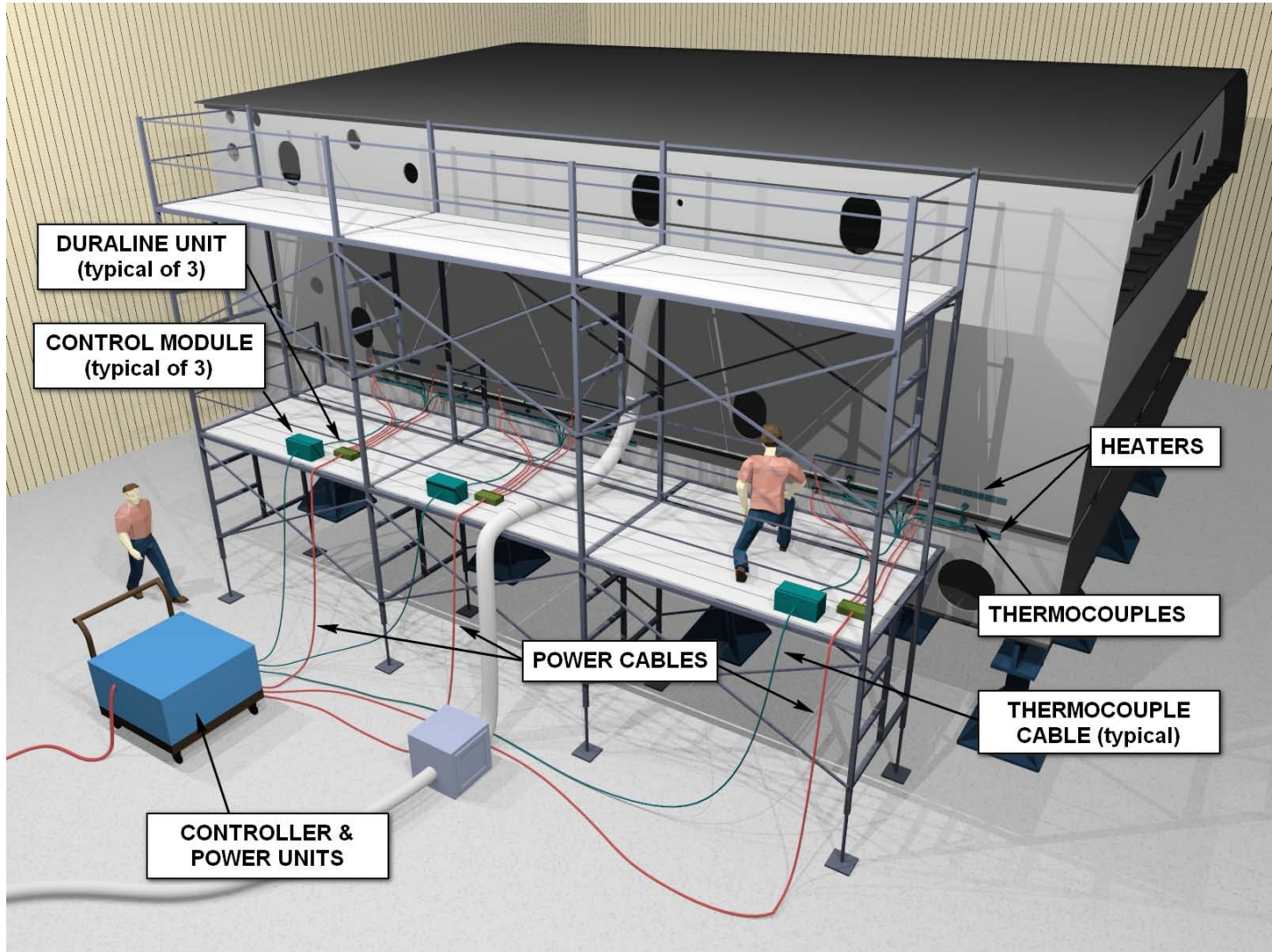

Modular Version

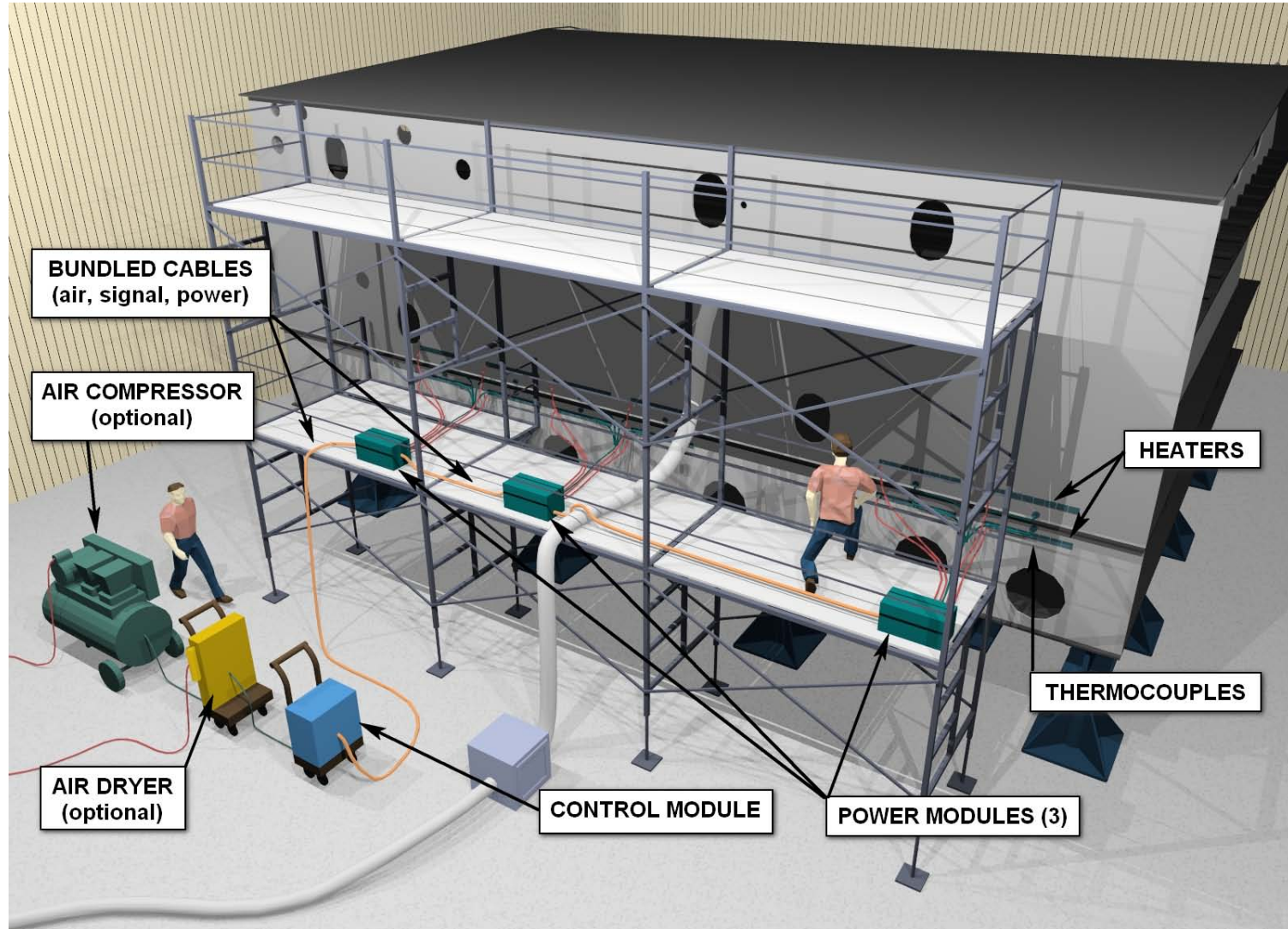

Modular Approach

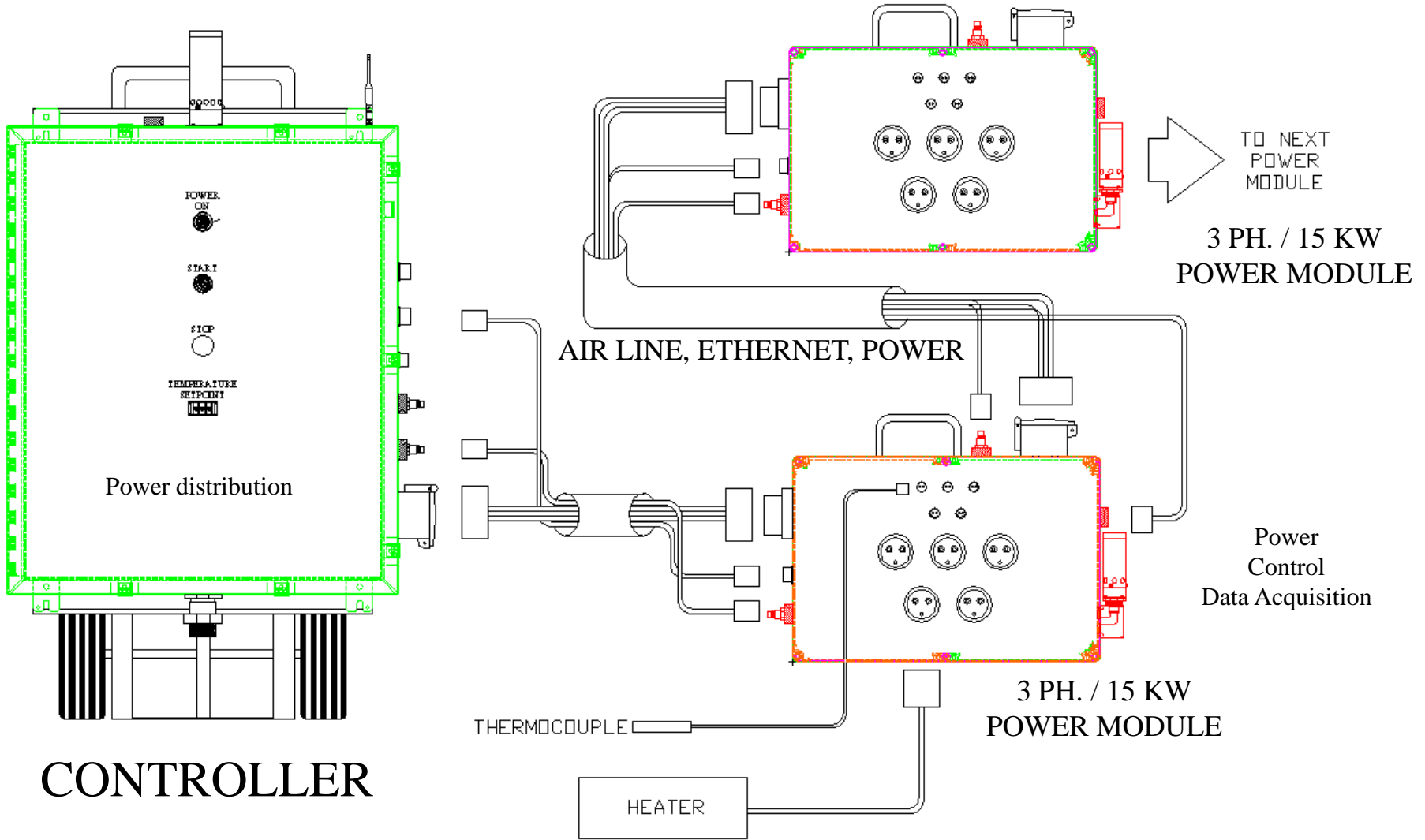

Modular Approach: Advantages

- Scalable: Plug in any number of heaters (75KW max)
- Scalable: Easily modified for 1 or 2 heater application
 - Data acquisition not needed
- Localized control and alarms at each Power Module
- SCR Controlled – Improved performance
- Outdoor use rated
- Individual pieces relatively lightweight
 - (~40 lb Power Module)
- Fairly simple to connect devices
 - Keyed connectors
 - Does not require matching of thermocouples with heaters

Modular Approach: Disadvantages

- Weight of Power Modules is more than weight of thermocouple enclosures

- Compressed Air Cooling
 - Adds additional air hose connection to the module
- Refrigeration Unit
 - Adds significant weight to module (exceeds 50 lb requirement)
- Enclosure Fan
 - Opening in enclosure can impact outdoor rating
- Passive Cooling
 - Can only be used with analog control/thermocouple signals (prevents daisy-chaining of signal connections)

Power Module (Passive Cooling)

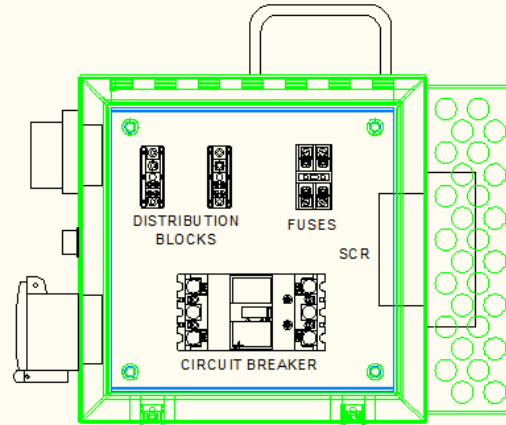

ENCLOSURE SIZE: 16" x 16" x 8"
THRU-WALL HEATSINK
APROXIMATE WEIGHT: 35 LBS

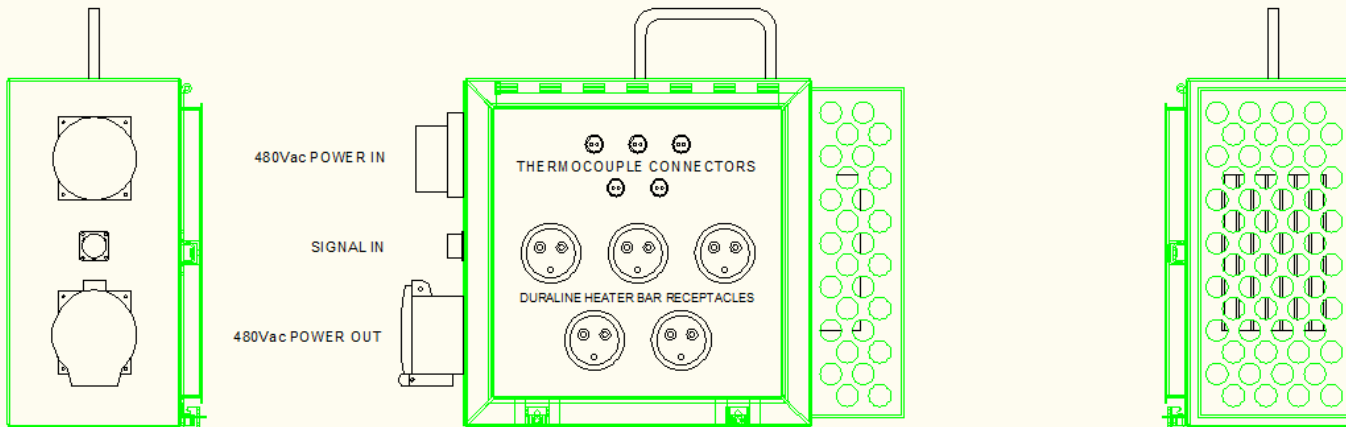

Power Module (Compressed Air Cooling)

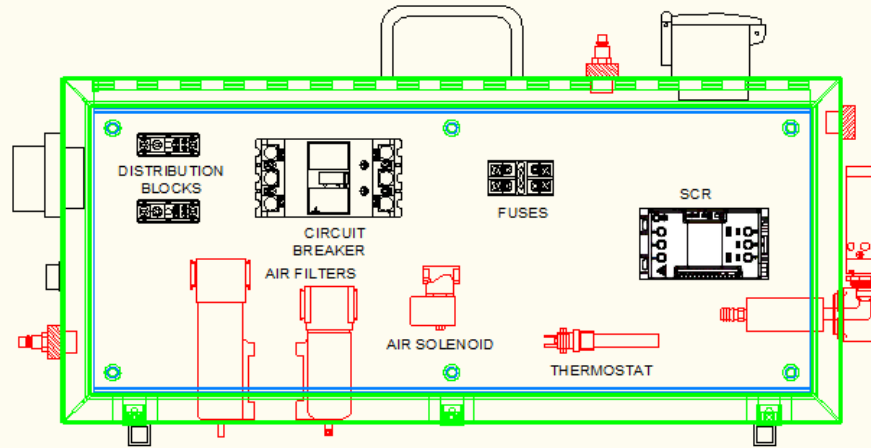

ENCLOSURE SIZE: 36" x 16" x 8"
 COMPRESSED AIR COOLING
 APPROXIMATE WEIGHT: 50 LBS

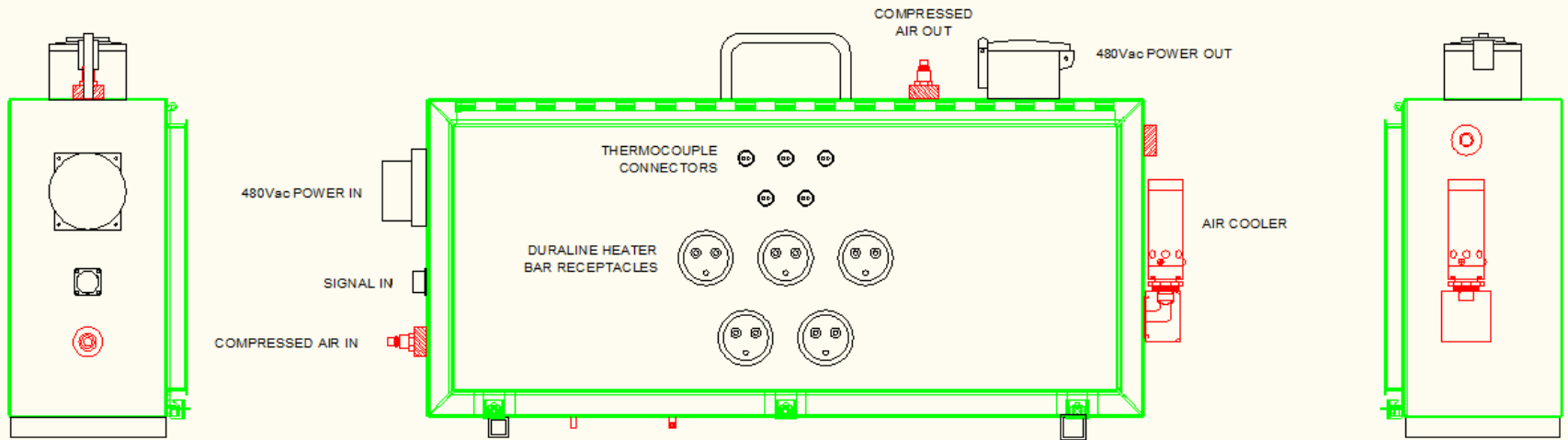

18 kW Unit: Advantages

- Control, power distribution and data acquisition in one box
- Minimal connections required
 - Power in, Power out, Compressed Air, Thermocouples
- Outdoor use rated
- Three zone SCR control
 - Allows control of heater pairs

18 kW Unit: Disadvantages

- More Costly to meet 75 KW/system requirement
 - Requires 5 units for 75 KW total
 - Each unit requires separate input power feed
 - One 1 KW unit per 6 heater Duraline block
- Does not meet 1 man lift requirement
 - Weighs more than 50 lbs



Options Summary

		Custom			
		Single Unit Version	Distributed T-Couples	Modular Version	18kW Unit Version
SYSTEM REQUIREMENTS/CAPABILITIES					
Communications	Format	Ethernet	Ethernet	Ethernet	Ethernet
Electrical (System Ratings)	Input Voltage (3-phase VAC)	480VAC	480VAC	480VAC	480VAC
	Service Required (A)	90A	90A	90A	90A
	Rated Power (kW)	75kW	75kW	75kW	expandable to 75kW (5 units)
Electrical (Heater Ratings)	Output (Heater) Voltage (single-phase VAC)	480VAC	480VAC	480VAC	480VAC
	Resistive heating	heater bar	heater bar	heater bar	heater bar
Physical Specifications	Weather Rated	yes	yes	yes	yes
	Durable Casing	yes	yes	yes	yes
	Carrying Weight Restrictions (max)*	<30lb	<30lb	~40 lb	50+ lb
	Size Restrictions	riggable/portable	riggable/portable	riggable/portable	riggable/portable
Closed loop Requirements	t-couple type	K	K	K	K
	t-couple quantity	yes	yes	yes	yes
Temperature Requirements	Maximum Temperature	250F+	250F+	250F+	250F+
Zone Control	# zones	fewer (6)	fewer (6)	most (not limited)	most (not limited)
Power Cables	Length	shortest	shortest	shortest	shortest
	Quantity	fewer (6)	fewer (6)	fewest	fewer
T-Couple Cables	Length	longest	shortest	shortest	shorter
	Quantity	most	fewest	fewest	fewer

* Carrying weight based upon components that would potentially need to be placed on a scaffold or upper level

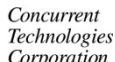
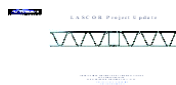

Single Unit Version

(centralized power and control; distributed temperature)

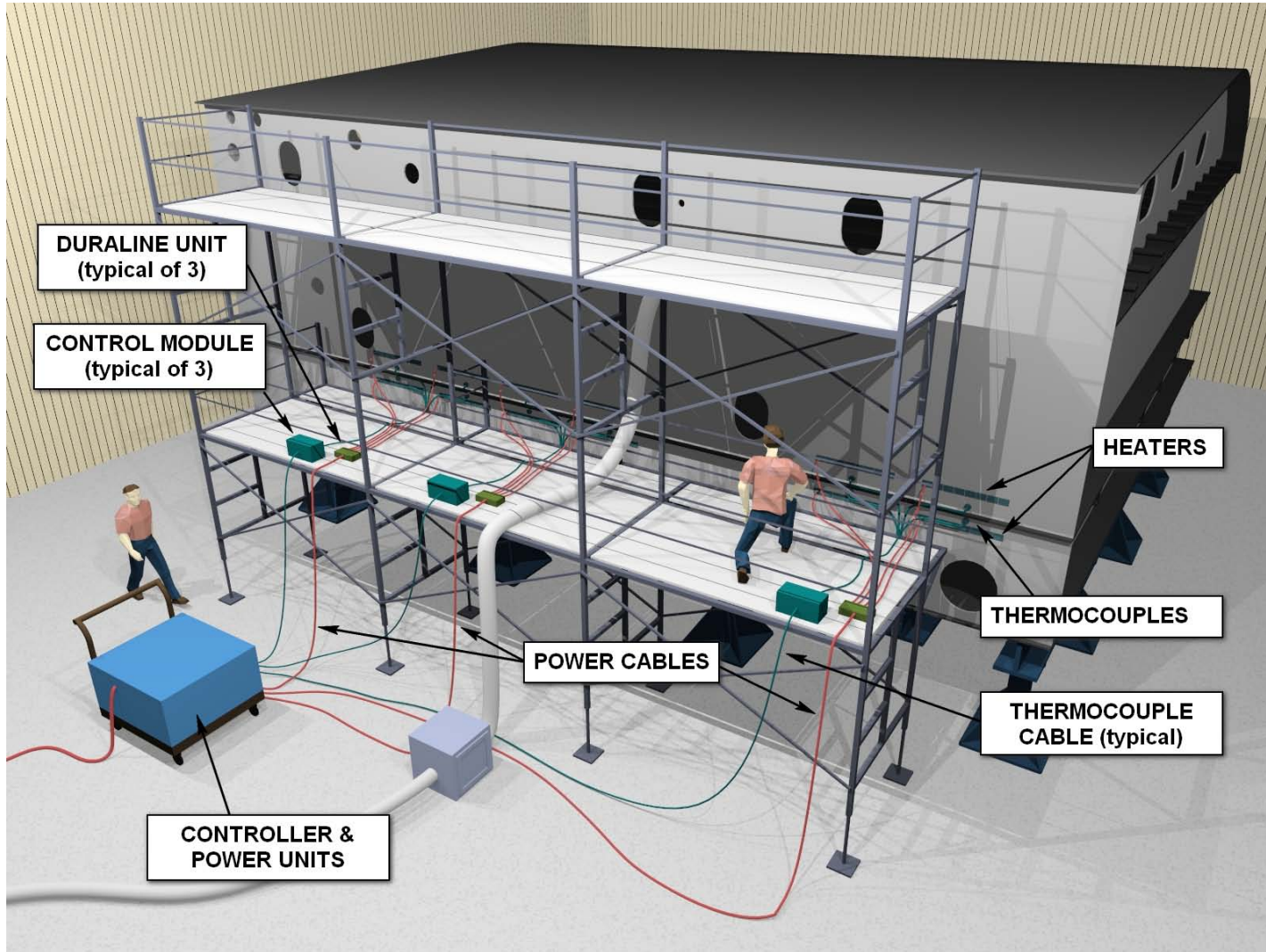

Modular Version

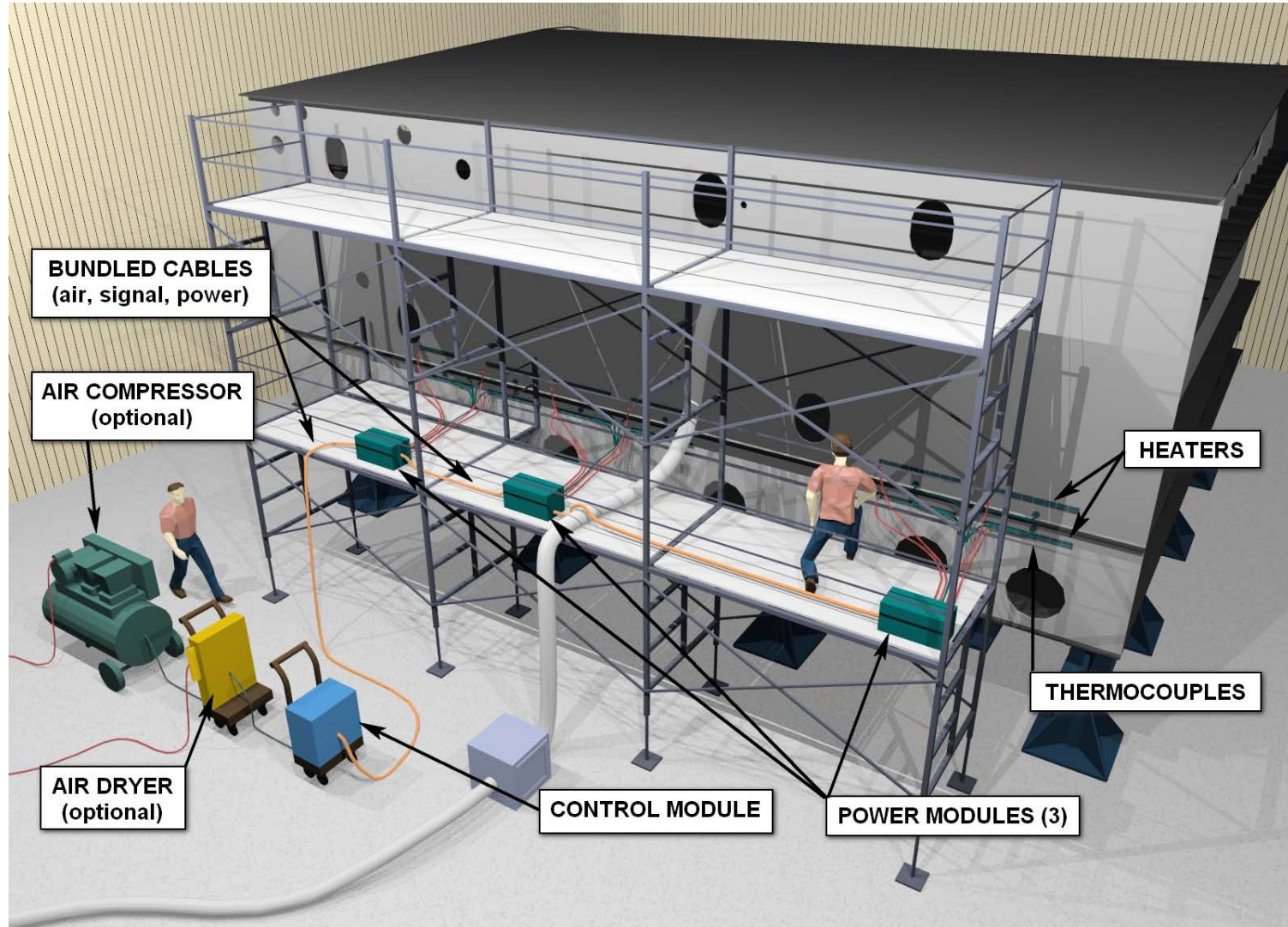



Advanced Metalworking Solutions for naval systems that go in harm's way

Technical Discussion / Feedback

Navy Metalworking Center A ManTech Center of Excellence



Concurrent
Technologies
Corporation

Contact Information

Clark Boriack
Sr. Electrical Engineer
Concurrent Technologies Corporation
Phone: (814) 262-2381
Email: boriackc@ctc.com