

Constructing a Prototype Man-Portable Friction Stir Welding System

Development Team: George Talia, Wichita State University, KS

Fred Callahan, Engineering Consulting Services, NC

NSWCCD Participants: David Forrest, Carrie Davis

NGSB-GC Participant: Lee Kvidahl

NSRP SP-7 Meeting
Idaho Falls, ID, 17 August 2010

Background

Development work with NSWCCD since 2008

- AA 5456, AA 5083, AA 6082
- Up to 0.25", mostly 0.125" single and double-sided
- Transverse tensile tests
 - 95% of base metal strength
 - Improved ductility (failure in parent metal)
- Good consolidation
- Forging forces from <100 lbs. to 400 lbs.

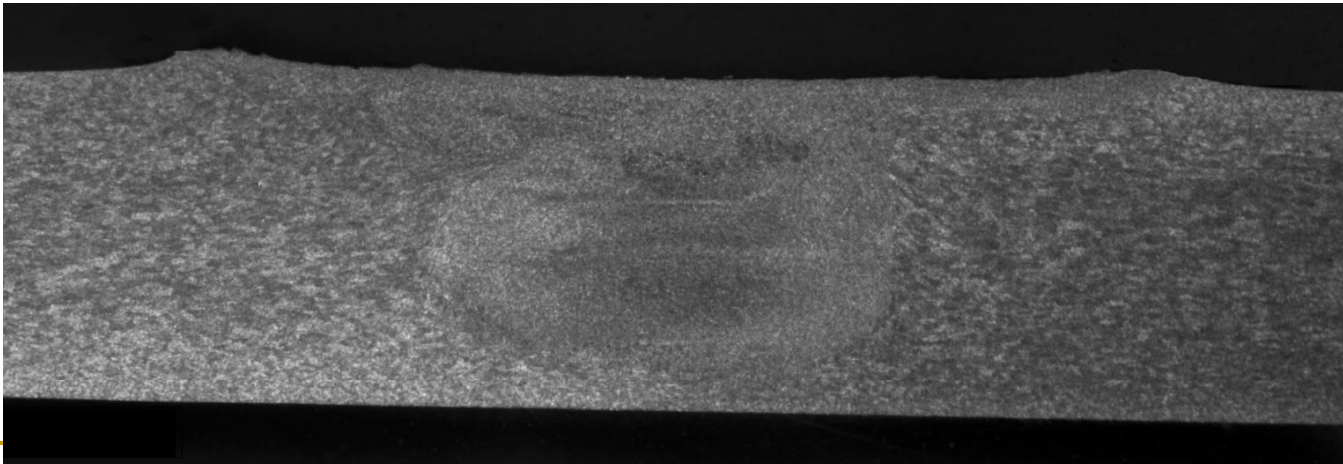

AA 5456, 0.125" thick

Project Description

- NSWCCD work: sufficient basis for proposal to build machine (2009)
 - Proposed
 - 100 lb. machine
 - Minimum 0.125" AA 5xxx plate, target 0.375"
 - Didn't specify welding envelope
 - Visits
 - Northrop Grumman Gulf Coast
 - LCAC Repair facility
 - Norfolk (CG repair)
-

Progress

- 16 March 2010: Pascagoula
 - Tour with Lee Kvidahl
 - Fabrication issues
 - Finalized target—3/8" plate, 40 foot
 - Guided the design envelope of 4' length welds
 - 13 July 2010: Panama City
 - Tour with Glen Campbell
 - Repair issues
 - Design decisions: May
 - Parts delivered: early July
 - Assembly: now
 - Spend down: \$41k billed, \$35k soon
-

Progress

- 24" x 54"+ envelope
- 175 lbs.
- Vacuum hold-down
- PLC-driven
- Position control only
- Teach points

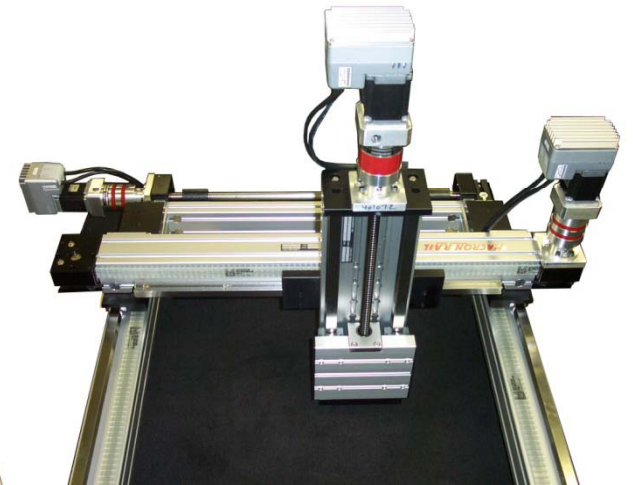

- 48" x 72" envelope
- 700 lbs.
- Vacuum hold-down
- PC-driven (LabView)
- Position and force control

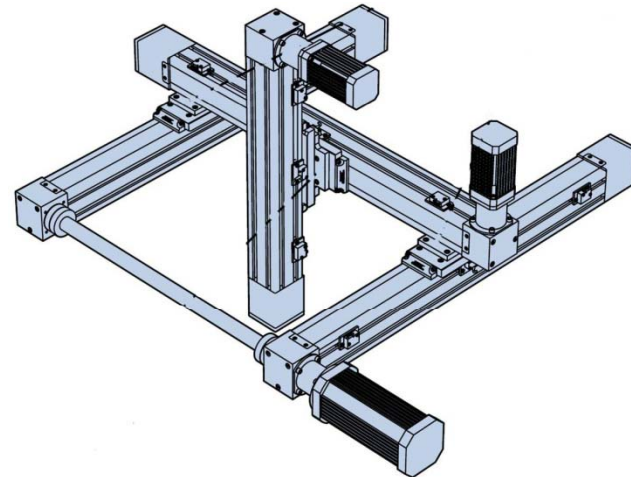

Remaining Tasks

- Finish assemblies
 - Programming (Aug-Sept)
 - System shake down (Sept-Oct)
 - Develop process parameters for 3/8" plate
 - Demonstration welds (expected by Dec-Jan)
 - Invitation to NSRP members
 - At Ingalls
-