

# *Advances in Marine Paint Handling Practices*

*NSRP – 2005 Conference  
Las Vegas*



Richard Parks  
25 January 2005

# Presentation Overview

- Development of Soluble Salt meter
- Navy Paint Systems
  - High Solids & Traditional Coatings
  - Packaging, handling, mixing, wastes, quality
- Identification of alternative packaging
  - Newport News Leadership & Current Focus
  - Process improvement and cost reductions
- Advances in Packaging and Handling
  - Disposable Paint Cartridges
  - Advanced mixing methods
  - Rolling & Spraying

# Soluble Salt Conductivity Meter

- Bresle Patch
  - Typical test takes ~ 10 – 12 minutes
  - Labor intensive, requires use of syringes
  - Patches expensive ~ \$ 6.50/each
    - One time use
    - Leaves contamination on surface
  - Results not reproducible

# Soluble Salt Conductivity Meter

- *Patent Pending Invention*
  - Eliminates Bresle Patch
  - Exactly replicates current process
  - No consumables
  - Rapid conductivity measurements
- Footprint exactly matches Bresle Patch - 1,250 mm<sup>2</sup>
- Self Cleaning between tests
- Software for data storage
- Coordinating development with NAVSEA 05M1



# Soluble Salt Conductivity Meter

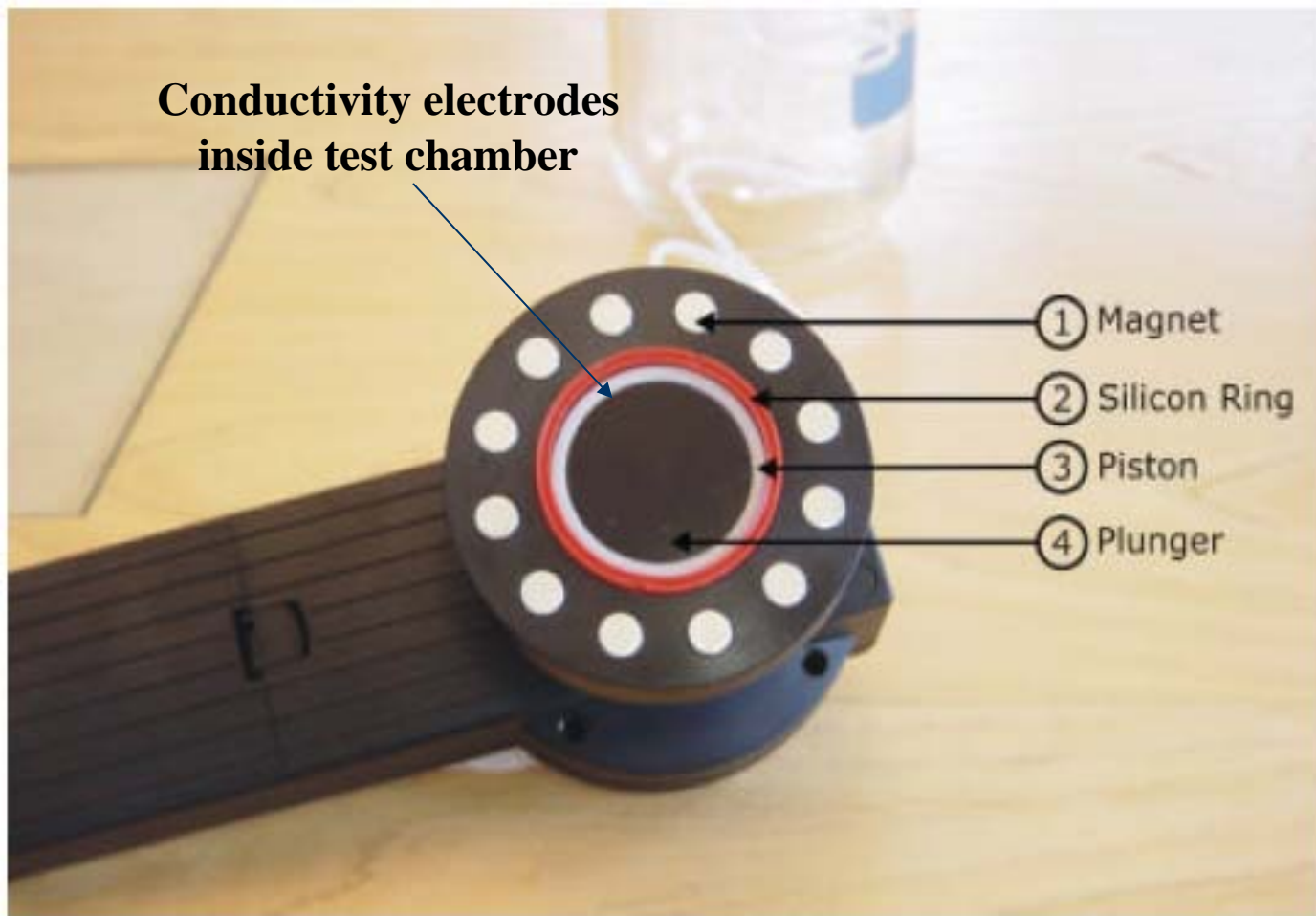

# Soluble Salt Conductivity Meter



LED readout



# Soluble Salt Conductivity Meter

Water injected into test chamber  
Using specially designed dispenser

Attaches to belt for easy handling

Exact dose of water delivered  
 $3.0 \text{ ml} \pm 0.04 \text{ ml}$

More accurate delivery than syringe

Test sequence is ~ 1 minute



# Soluble Salt Conductivity Meter

Data Storage and Download

USB port for computer



# About this Briefing:

- This briefing addresses a departure from traditional paint packaging and mixing systems
  - Primary focus is on maintenance & repair systems
  - Does not address bulk installations of coatings
- Effort fully endorsed by NAVSEA 05M1

# Engineering Support Provided to Newport News

- Newport News requested RPCT assistance to identify all inefficiencies in coating application and handling practices for small jobs
  - **Improve efficiency and accuracy**
  - **Reduce labor costs**
  - **Meet/exceed environmental regulations**
  - **Reduce coating waste in handling, using, and disposing of paint materials and related processes**
- Identify & assist in implementation of innovative paint handling technologies

# Goals

- Key engineering goals addressed to offset these inefficiencies:
  - Eliminate need to open & pre-mix & mix marine paints from 5-gallon cans
  - Decrease/eliminate excessive waste stream
  - Deliver the paint at work site ready to mix/use
  - Remove any issues concerning poor mixing or off-ratios
  - Achieve worker buy-in and support

# Lost Productivity at NGNN - Paints

- **28% of the production observations on CVN 76 was due to walking**
- **Getting paint material represents 90% of the lost time in traveling**
- **One hour each morning is contributed to getting paint products**
- **Handling paint waste such as draining 5-gallon buckets and carrying them to the waste site also takes away from productive hours**

# Paint Dispensing Process Opportunities

- Paint Waste
  - Mixed paint more than needed
  - Paints typically mixed from remote sites
  - Unused Paint @ End of Shift
- Disposal Waste Stream
  - 5-gallon paint cans
  - Unused paint products
- Manual Dispensing Method Cycle Time
  - Long lines of painters waiting for “pour”
  - As high solid coatings are introduced with shorter and shorter pot lives the need for alternative handling practices are needed

# Solution Developed at Newport News

- RPCT's engineering and Newport News Management allowed:
  - Invent a method to pre-package marine paints in disposable dispensing cartridges
- Utilize cartridge configuration with disposable static mixers
- Provide ability to dispense Paint “As Needed”
  - On Time - When needed
    - **On Ratio**
    - **Fully Mixed**
    - **No-Waste**
  - No concerns with pot life

# Cartridges



# Packaging Of Marine Paints

- Packaging and dispensing system that:
  - Dispenses coatings in exact predetermined ratios
  - Dispenses varying ratio coating materials
  - Pre-mixes dispensed coatings via a multi stage static mixer
  - Virtually eliminates coating waste
    - 20% to less than 1%

# Cartridge Configurations & Improvements

Cartridge are available:

Sizes: 75 ml, 150ml, 300ml, 600ml, 750ml

Ratios: 1:1 up to 10:1

Hardening for Marine Paints:

Sealed/molded dispense end

Hermetic seal - Molded one piece design for stability

300 & 750 ml cartridges key requirement of Newport News

# Typical Cartridge Configuration

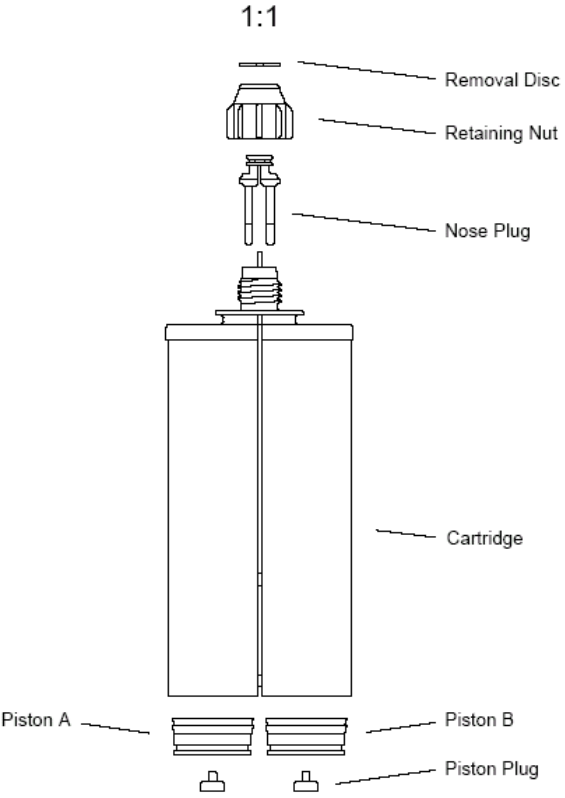

Mixing is determined by number of elements

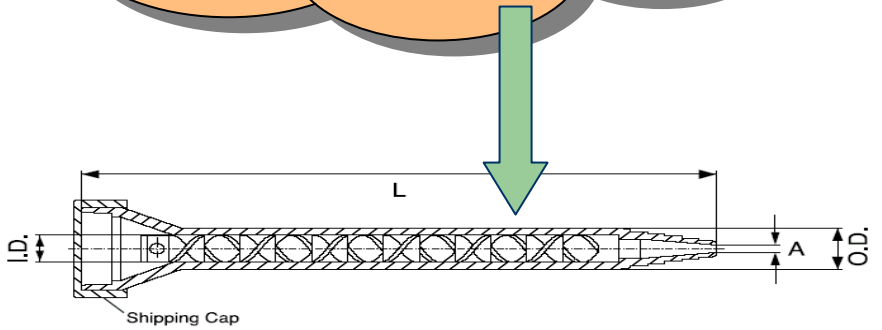

Mixed 2.1 million times

# Cartridge System



# Inserting Cartridge Into Dispenser



# Attaching Static Mixer and Securing Ring

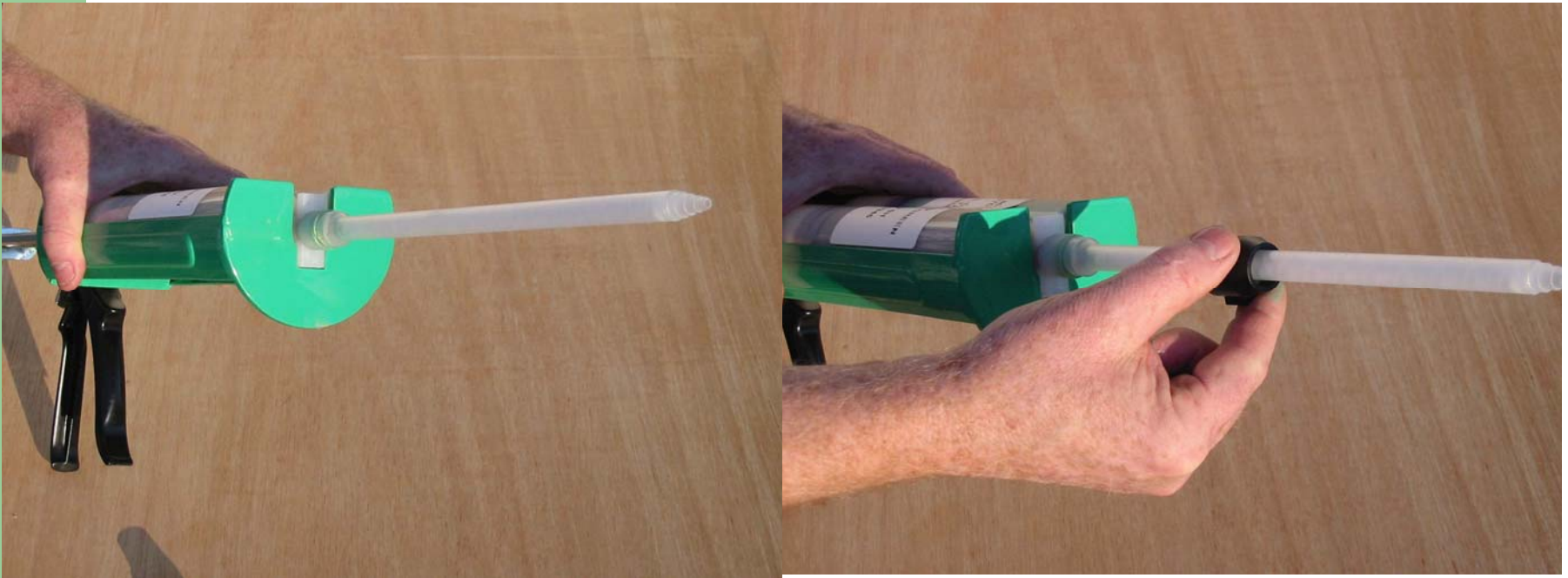

# Dispensing



Paint is mixed halfway through  
static mixer

# Dispensing

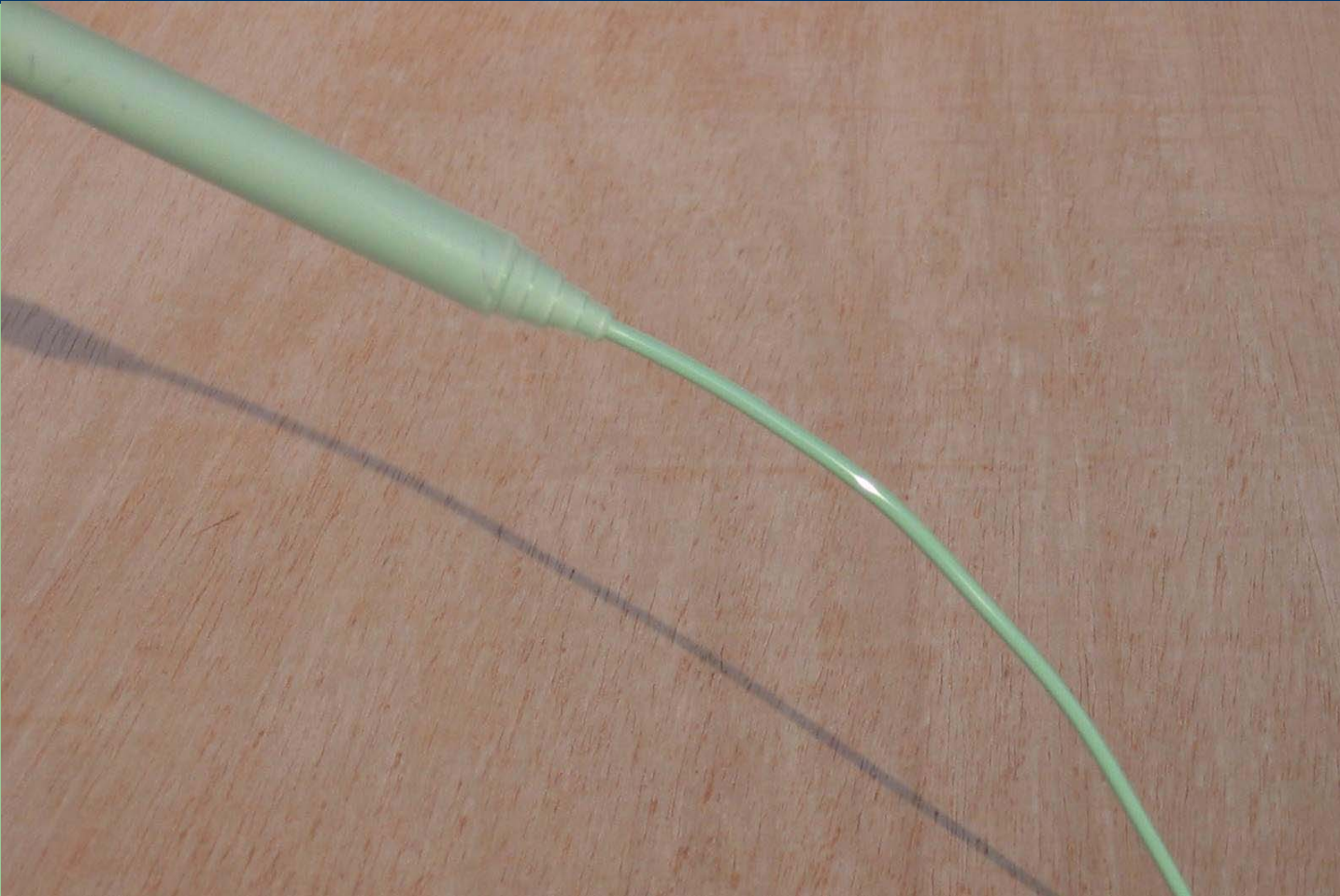

# International InterBond 998

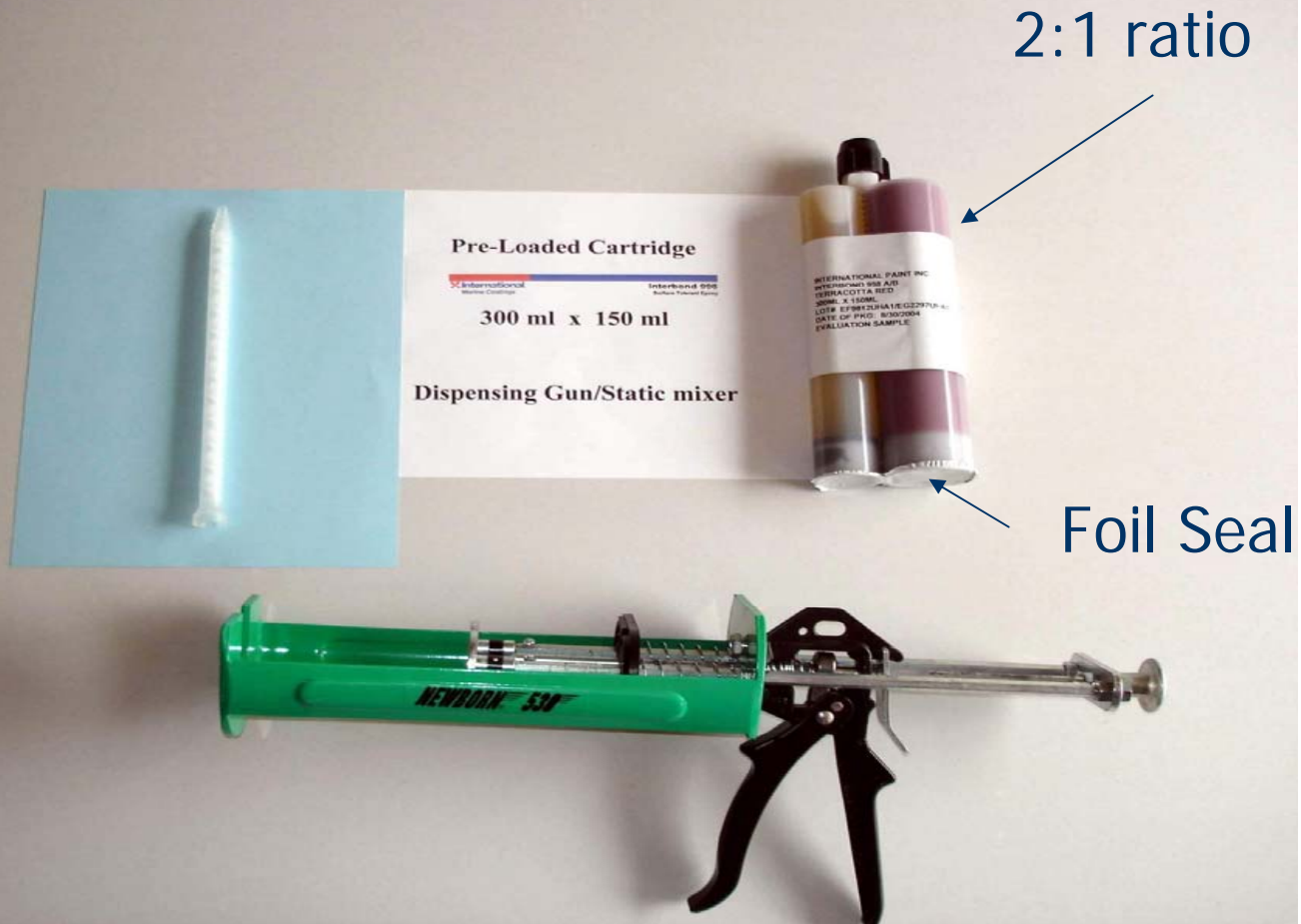

# International InterBond 998

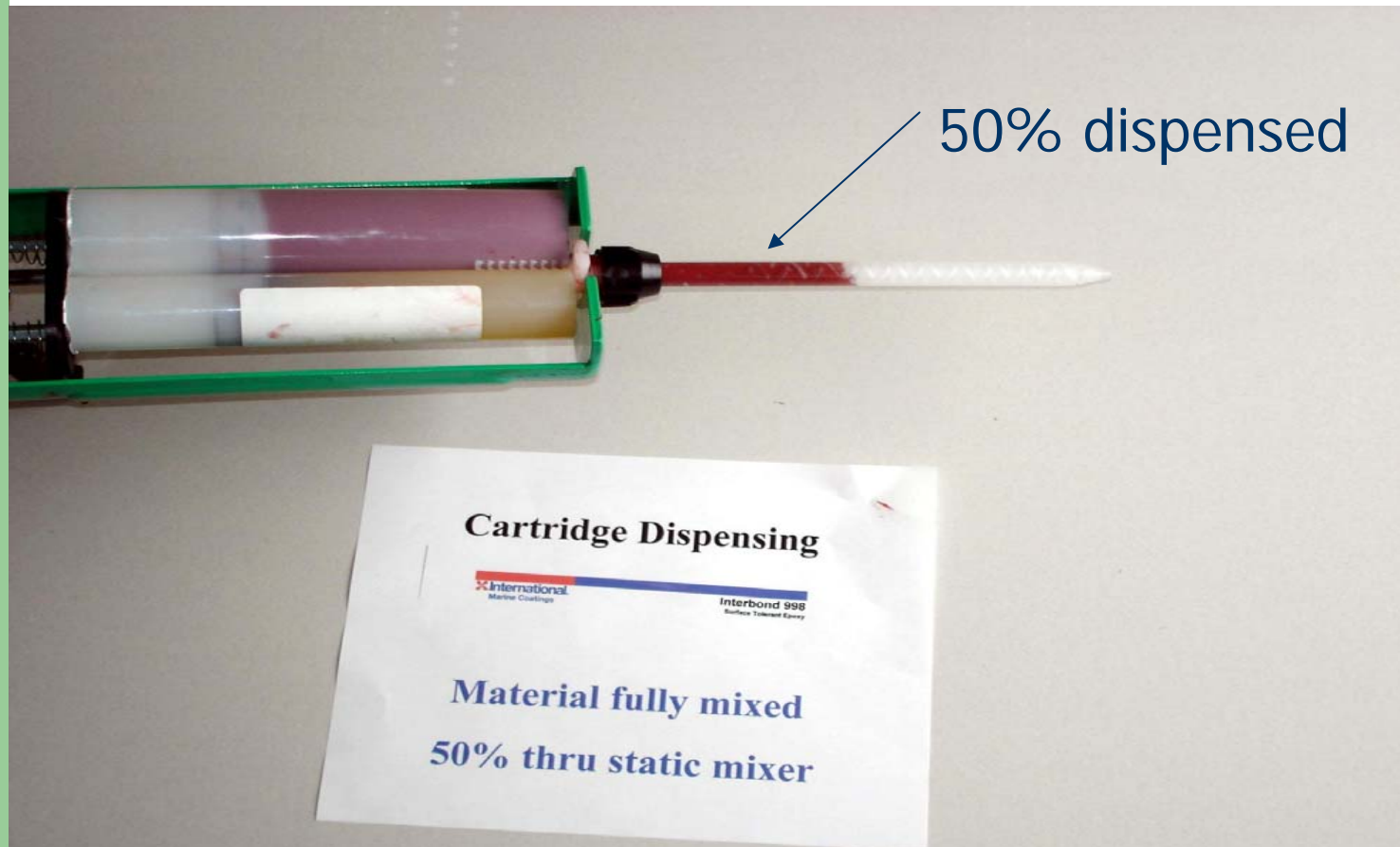

# International InterBond 998

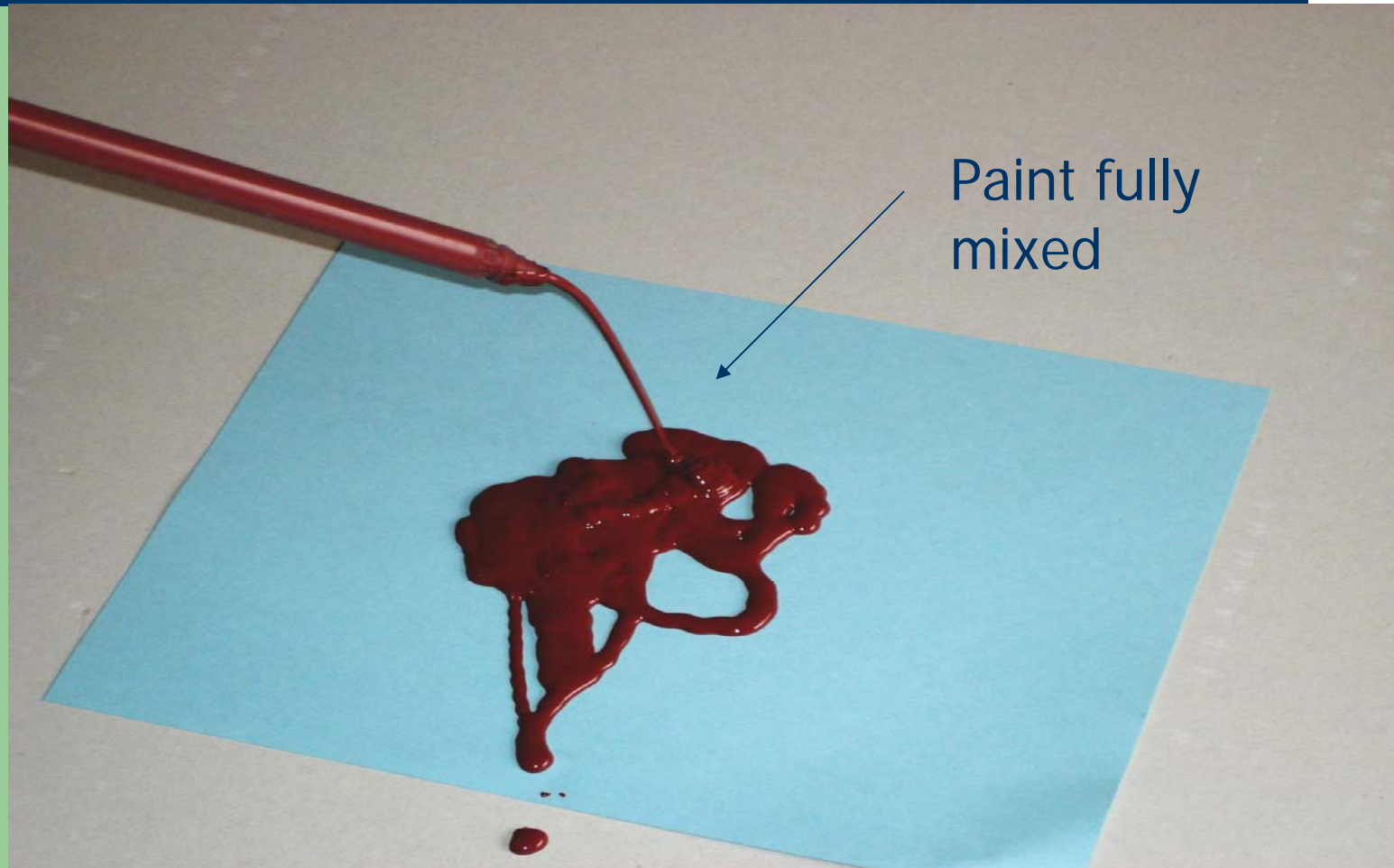

Paint fully  
mixed

# Benefits Identified By NGNN

- Eliminate long production lines for obtaining paints
- Eliminate guess work in mixing of paint
  - Perfect mix every time - “Fool-proof”
- Allows painter to carry more paint to job site
- Painter on the job longer
- Eliminate paint spills
- Reduction in VOC emissions
- Eliminate paint waste
  - Use only what you need
  - Waste reduced from 20% to ~1%
  - Reduction in disposal cost of hazardous waste
- Saves time/reduces labor

# Paint Company Involvement

- Navy QPL qualified paint manufacturing companies currently engaged
  - Staffing up to supply variety of cartridge configurations
  - Modifying stocking and tracking requirements
  - Currently gearing up to support Newport News conversion

# Leveraging

- Utilizing Plas-Pak Patented cartridge Technology
  - Allowed development of advanced equipments to meet the needs of the Navy repair community
  - Application techniques
- Newport News - Total package

# Working Advancements

- Invented plural component spray system for marine paints
  - Quadra Head dispensing machine
- Spray or roll stripe & repair coats
- Can dispense fully mixed high solid paints and rapid cure coating systems for tanks
- Focus is power straying and rolling coatings for tanks and bilges

# Quadra Head Plural Component Dispenser

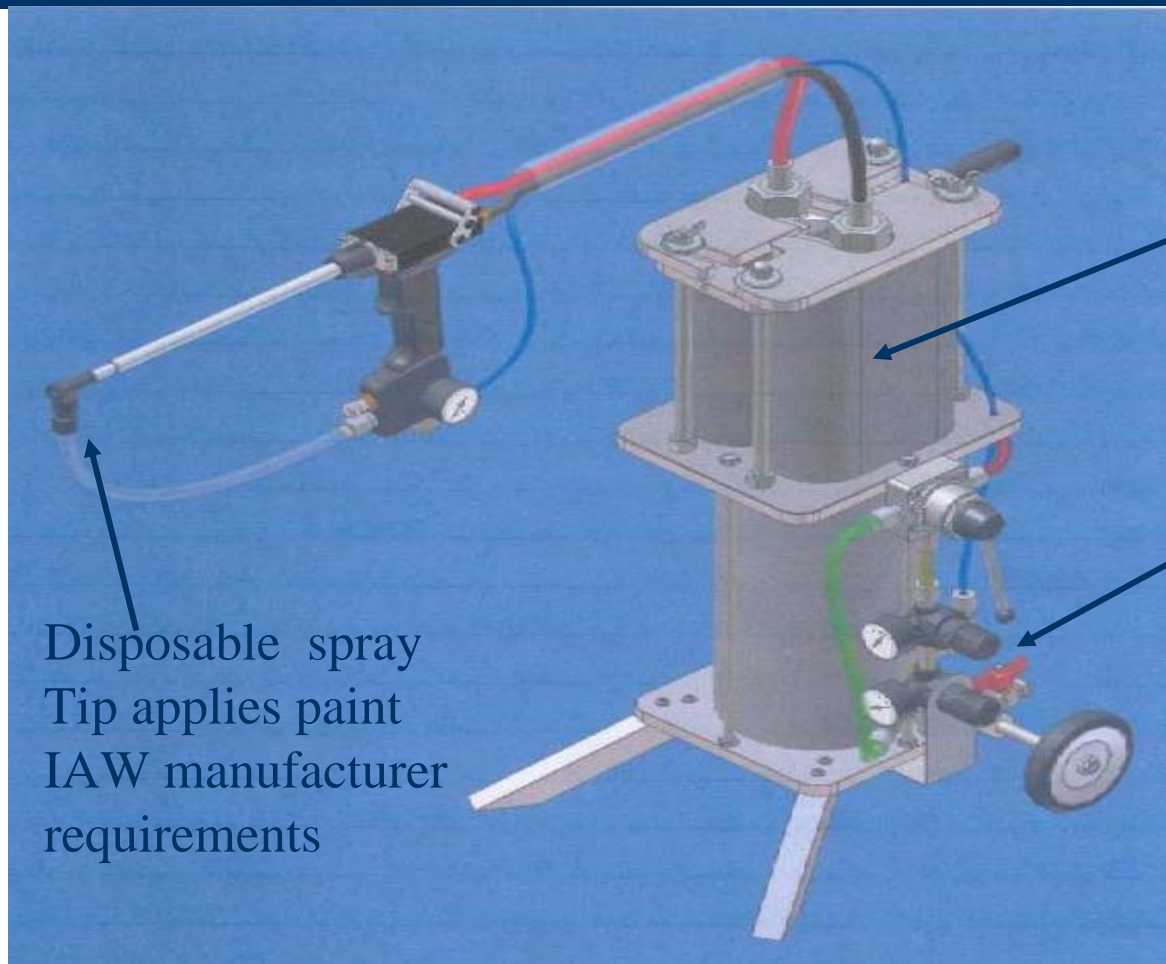

Holds 4 – 750ml cartridges

Low pressure Air Feeds system

Disposable spray  
Tip applies paint  
IAW manufacturer  
requirements

# Quadra Head Plural Component Dispenser

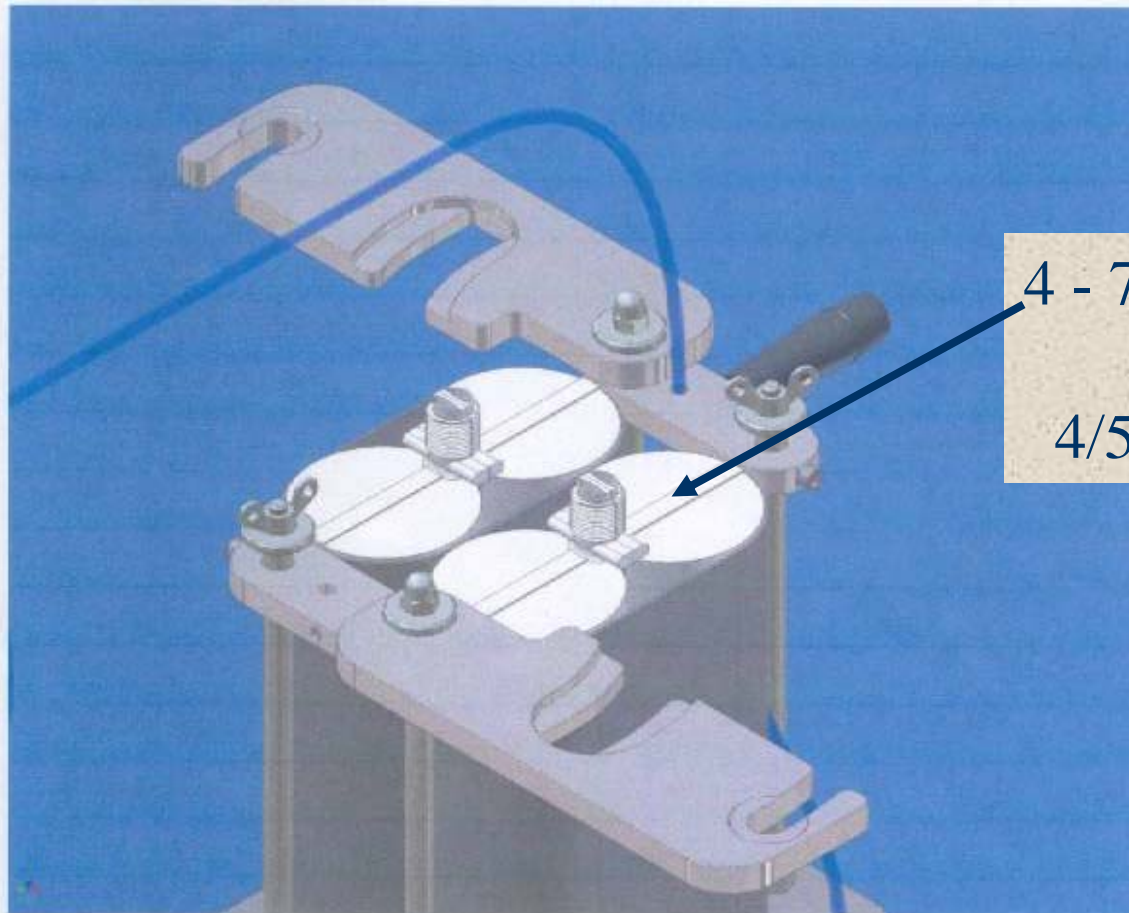

4 - 750 ml cartridges

4/5 gallon of paint

# Quadra Head Plural Component Dispenser

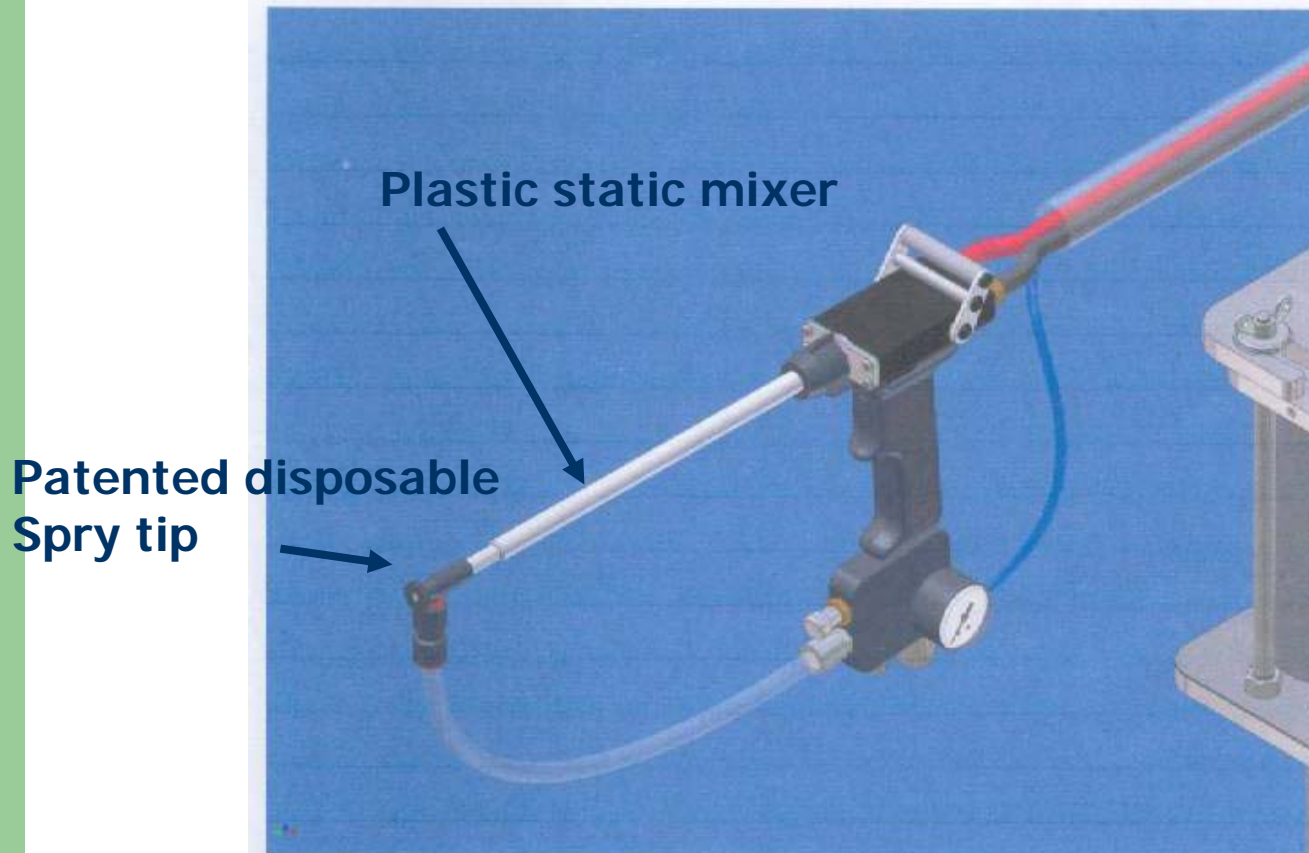

4-Cartridges  
4/5-gallon paint



Quadra Head Cartridge Spray System



Static Mixer

# Spraying



# Spraying



# Spraying



# Power Roller/ Power Spray



# Power Rolling F-150



# Cartridge Paint Shaker



# Ship/Wall Mounted Dispensing Unit

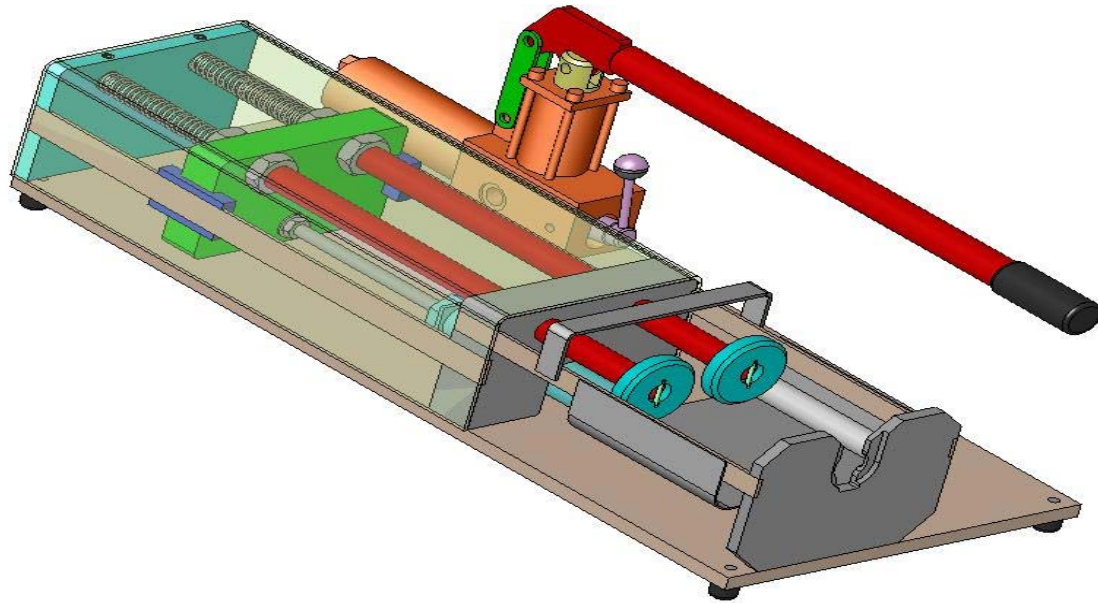

# Ship/Wall Mounted Dispensing Unit

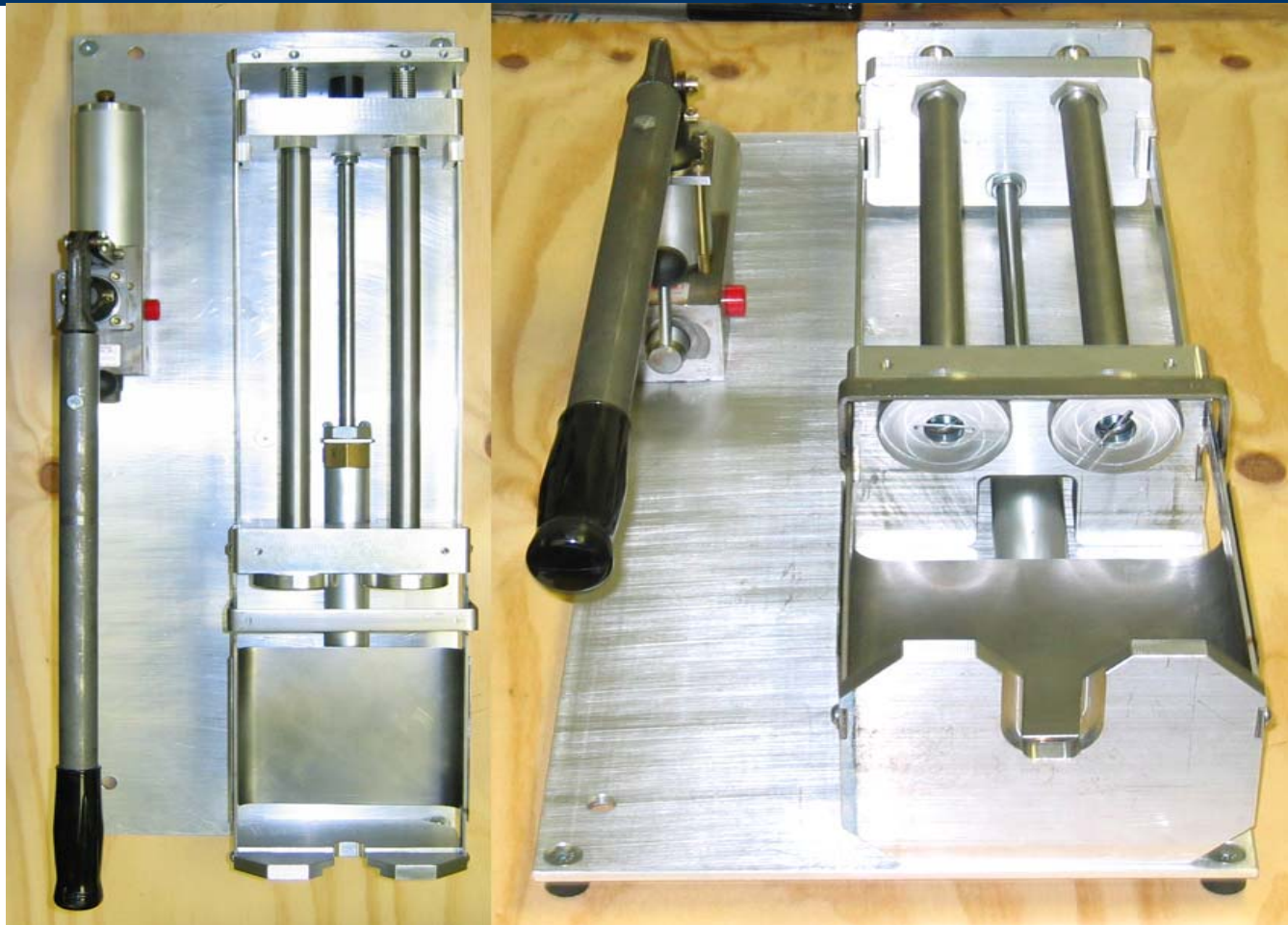

# Patents

- ◆ Cartridge Technology applied to limited market – not Marine or Industrial Paints
- ◆ RPCT has Utility Patent Pending on use of Cartridges and Dispensing Equipment in Marine & All Industrial Applications
  - ◆ Addresses method for dispensing, rolling, power rolling, brushing, and spraying marine and industrial paints

# Paint Supplier Agreements

- Patented technology is available *TODAY* from:
  - International Paints
  - Ameron Coatings
  - Sigma Coatings
  - Mobile Coatings

Several others agreements are currently pending