



NORTHROP GRUMMAN

RTT
ROBOTIC TECHNOLOGIES OF TENNESSEE

Robotic Technologies of Tennessee's
**Mobile Robotic Welding
System (MRWS)**

Robotic Technologies of Tennessee (RTT)
Northrop Grumman Ship Building, GC
Bath Iron Works (BIW)

Jamie Beard, Steve Glovsky
RTT

Supported in part by
NSRP, NSF, ONR

April 2011

“Trackless” Automation: RTT’s Mission:

Transform How We Work On Large Metal Structures

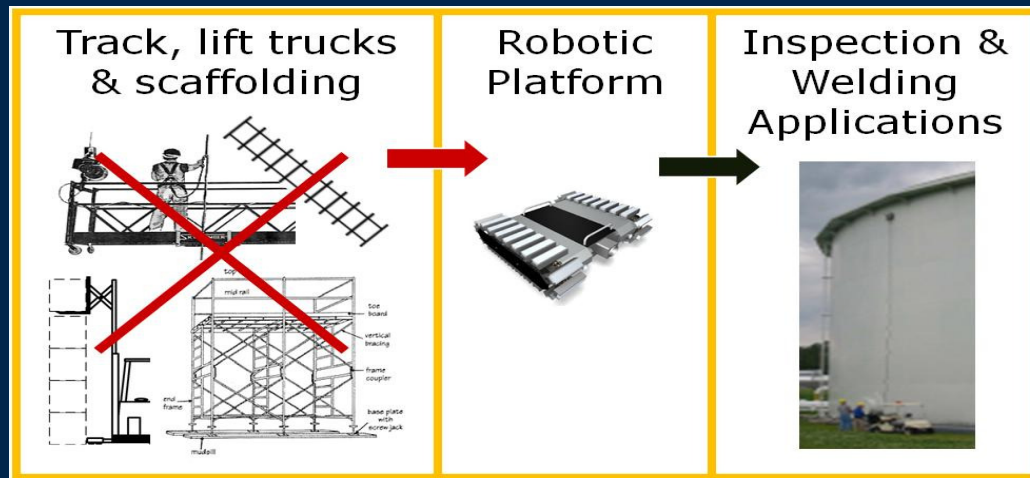
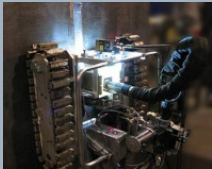
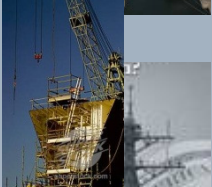
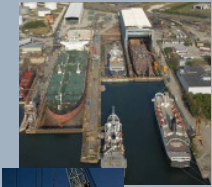

"Trackless" Automation: RTT's Mission:

We improve workers and work



Robotic Assisted
Worker

Worker With
Traditional Tools

How We Do It

Increase Productivity	Convert manual tasks to automated tasks
Eliminate Process Steps	Eliminates steps such as fixed tracks, scaffolding to reach work site, setup & take down time
Increase Safety	Remote operation removes worker from risk area and reduces stressful work postures
Improve Quality	Robotic control, automated data collection and feedback improves quality
Optimize Labor Mix & Flexibility	Allows less experienced workers to perform more complex tasks accurately and efficiently

"Trackless" Automation: How It Works

Base Unit
Crawler



Controller



Application
Attachments

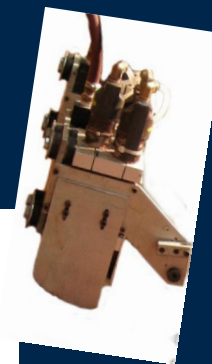
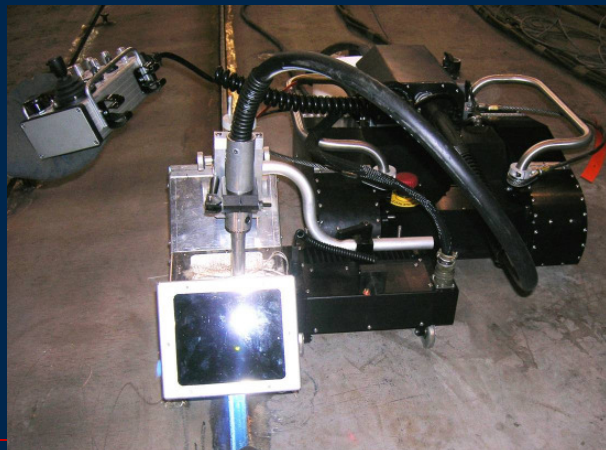

"Trackless" Automation: Two Systems

Crawler Units:

- MRWS
 - 80lb + payload
 - Autonomous & remote operation
- Onboard wire-feed
- Torch manipulator
 - 4 dof
 - 1 active, 3 manual



- MRWS-mini
 - 50lb + payload
 - "suitcase size"
- Highly portable
- Use with suitcase welder
- Torch manipulator
 - 4 dof
 - 1 active, 3 manual

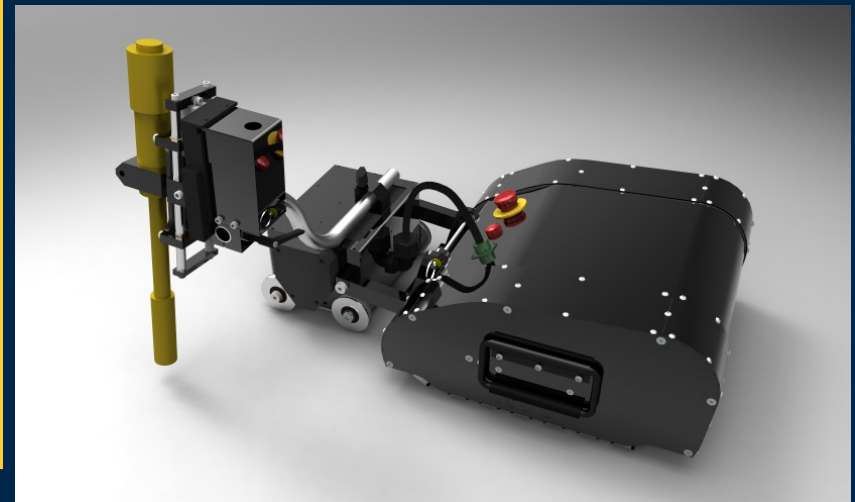

"Trackless" Automation: Options

MRWS Torch Manipulator Options

□ Torch manipulator - Manual

- 5 dof torch control
 - 2 closed-loop control
 - 2 knob control
 - Torch depth
 - Work angle
 - 1 clamp control
 - Travel angle

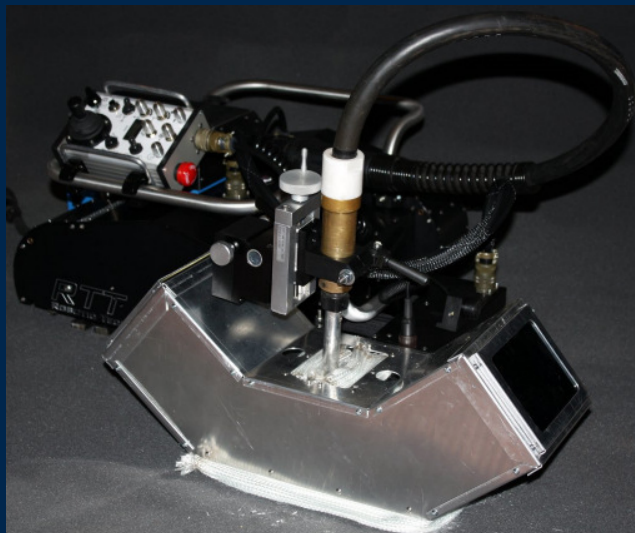

□ Torch manipulator - Remote

- 5 dof torch control
 - 4 closed-loop control
 - Remote access
- Position feedback on all axes

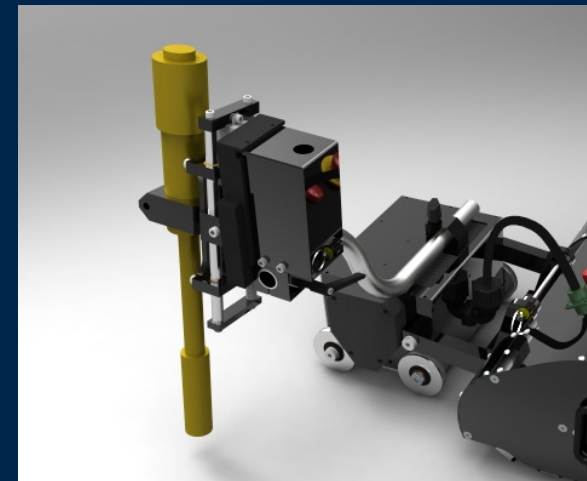

"Trackless" Automation: Options

MRWS Operator Controller Options

□ Tethered Operator Controller

- 6' – 50' lead
- Controls Robot + Torch manipulator
- Simple, intuitive to use
- Stores up to 30 weld system settings



□ Wireless Operator controller

- Ruggedized controller pad with hardware buttons
 - 2-way communication
 - Video feedback
 - Process status
 - Control all dof remotely
- ### □ Access from any network system



"Trackless" Automation: Options

MRWS Camera Options

- MRWS Video feedback
 - During arc viewing
 - Pre/post arc viewing
 - Feedback incorporated with controller
 - Control video prop's remotely
- MRWS Seam-tracking
 - Vision-based
 - Closed-loop seam tracking during operation

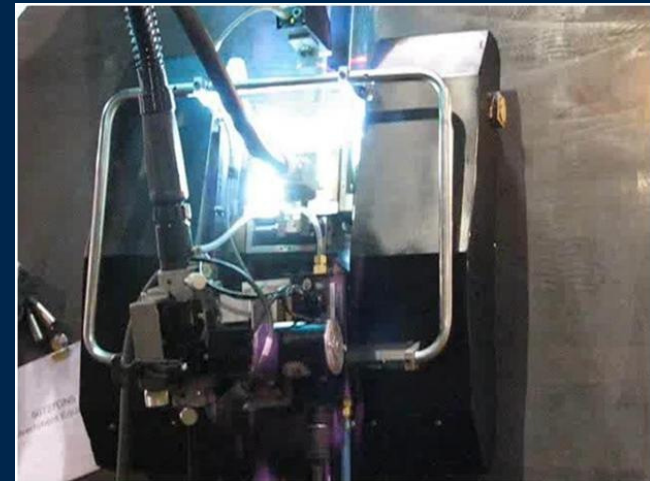
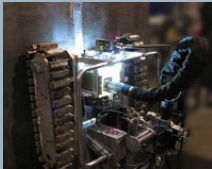

Evaluation

- Test comparisons: four systems compared:
 - MRWS-R (remote welding system)
 - MRWS
 - Mechanized (track-based)
 - Manual
- Job:
 - 20' vertical butt, $\frac{3}{4}$ inch material, 4 weld passes
 - 1/3 of scaffold costs contributed to welding job
 - 30 minutes to get mechanized equipment to job, 30 minutes return
 - 3 hour track setup time, 1.5 hour take down
 - Manual welder operates at 50% rate of mechanized tool

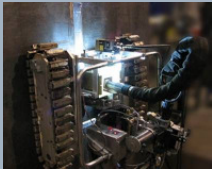
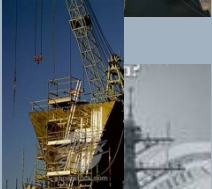

Evaluation results

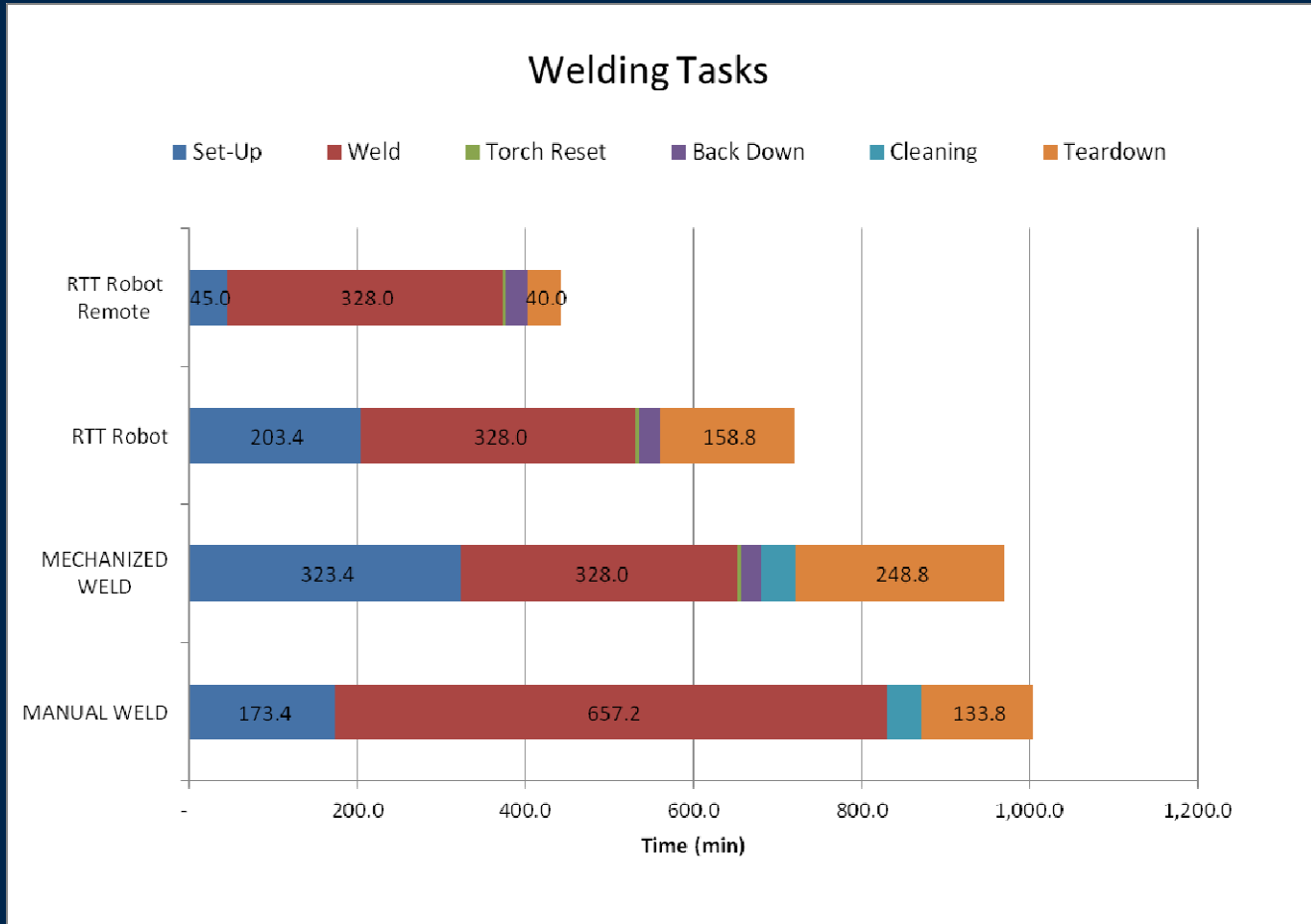
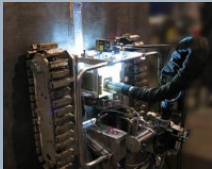
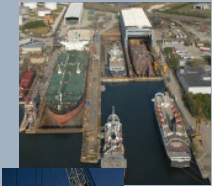

Evaluation Results

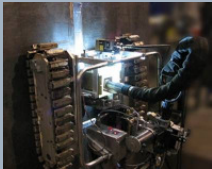
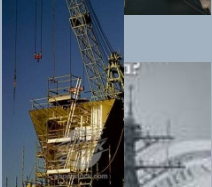
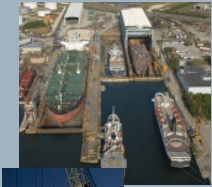

	MANUAL WELD	MECHANIZED WELD	RTT Robot	RTT Robot Remote
Set-Up	173.4	323.4	203.4	45.0
Weld	657.2	328.0	328.0	328.0
Torch Reset	-	6.0	3.6	3.6
Back Down	-	24.0	25.8	25.8
Cleaning	40.0	40.0	-	-
Tear-down	133.8	248.8	158.8	40.0
Totals	1,004.4	970.2	719.6	442.4

Current Status and Future Directions

- Continued in-field assessments
- Introducing new developments
 - "At-Distance" operation (NSRP PI)
 - Wireless interface
 - Real-time Weld system monitoring
 - Automatic depth control (NSRP PII)
 - MRWS – mini in wider range of weld tasks

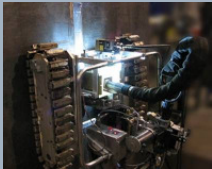
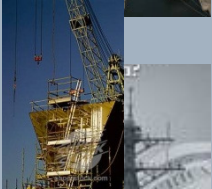
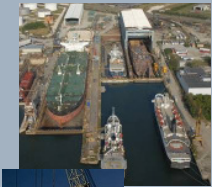

"Trackless" Automation: How it Works

- Fully Mobile, climbing tractor
- Can carry and manipulate applications
- Remote and Automatic operation
- Can climb in any orientation, even upside down
- Magnetic track system
- Automatic guidance
- Control of weld functioning
- Welding types targeted: erection joints & horizontal seams

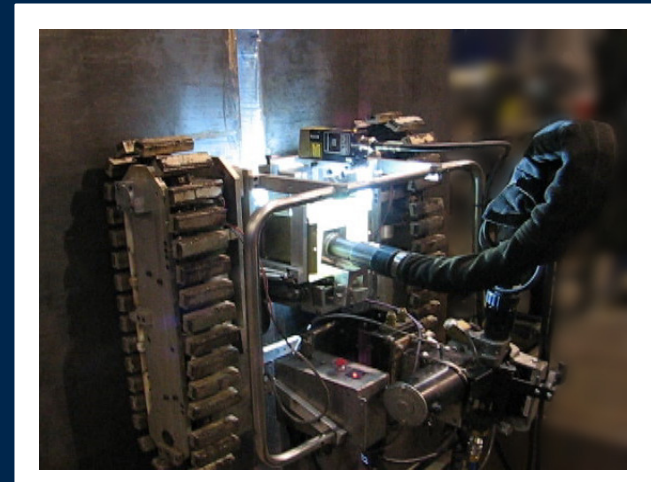

"Trackless" Automation: Applications:

Inspection: (boilers, tanks, penstock, pipes, etc.)

Available Now

Target industries: Waste energy, traditional energy & alternative energy

Welding: (bulk head erection, hull assembly & long seams)

Final field testing stage

Target industries: Shipbuilding & fabrication facilities & construction firms doing long seam welds

Maintenance (cleaning, surface prep, paint removal, etc.):

Available Now

Target industries: Waste energy , traditional energy & alternative energy

Cutting: *Coming Soon*

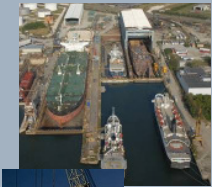

Presentation Overview

- Demonstration
 - Setup, Weld, Takedown
- RTT Objectives/Mission
- Current System, configuration options
- Sample Evaluation
- Current Status and Future Directions

